



# 8526 Series

## Applications

For all general purposes in Mil/Aero area.

## Standards

NFC 93422 - HE 312  
D TAT C 5935 x 0001



## Description

- Intermateable and interchangeable with MIL-C 26482G Series I and II DIN 29504 and PAN 6432-1
- Aluminum alloy olive green or nickel plating
- Bayonet coupling
- Gold plating crimp contacts
  - # 20, 16 and # 12
  - # 16 and # 12 coaxial contacts
- Hermetic versions available

## Characteristics

### Mechanical

- Endurance : 500 operations
- Shock : according to NFC 93422 - HE 312
- Vibrations : 10 to 2000 Hz, 20 g
- Contact retention in insert :
  - size 20 : 90 N
  - size 16 : 115 N
  - size 12 : 133 N

### Electrical

- Max current rating per contact :

	environmental class	hermetic class
size 20	7,5 A	5 A
size 16	13 A	10 A
size 12	23 A	17 A

- Contact resistance :

	environmental class	hermetic class
size 20	$\leq 1 \text{ m}\Omega$	$\leq 7 \text{ m}\Omega$
size 16	$\leq 0,55 \text{ m}\Omega$	$\leq 3,8 \text{ m}\Omega$
size 12	$\leq 0,35 \text{ m}\Omega$	$\leq 2,4 \text{ m}\Omega$

- Insulation resistance :  
 $\geq 5000 \text{ m}\Omega$  at 500 Vdc

- Dielectric withstanding voltage 2 classes : services I and II

Service	I	II
at ground level	1500 Vrms	2300 Vrms
at 21000 m	375 Vrms	550 Vrms

- Shell continuity :
  - environmental receptacle  $\leq 5 \text{ m}\Omega$
  - hermetic receptacle  $\leq 50 \text{ m}\Omega$

- Resistance to fluids :  
according to NFC 93422 - HE 312

### Climatic

- Operating temperature :
  - 55°C to +200°C (class N)
  - 55°C to +175°C (class G)
- Damp heat : 56 days
- Salt spray : 48 hours
- Leakage :
  - environmental version :**
    - when mated under a differential pressure of 2 bar, air leakage is  $\leq 16 \text{ cm}^3 / \text{hr}$
    - low pressure immersion : 33 mbar
  - hermetic version :**
    - differential pressure of 1 bar air/helium, leakage is  $\leq 2,8 \text{ mm}^3 / \text{hr}$

## Ordering information

### Environmental connectors

<b>basic series</b>	<b>8526 00 G 10B6 P N ..</b>
<b>shell type</b>	<b>00</b> - square flange receptacle <b>07</b> - jam nut receptacle <b>36</b> - RFI shielded plug <b>16</b> - plug
<b>plating</b>	<b>G</b> - olive green cadmium <b>N</b> - nickel
<b>contact layout</b>	- see table p 50
<b>contact type</b>	<b>P</b> - male contact <b>S</b> - female contact
<b>orientation</b>	<b>N</b> - normal <b>W, X, Y, Z</b> - see table p 51
<b>specification</b>	<b>L</b> - supplied without contacts - connectors supplied without backshell, with standard contacts : without digit - specification for connector supplied with backshell and standard contacts : <b>01</b> - backnut <b>02</b> - straight cable clamp <b>03</b> - elbow cable clamp <b>17</b> - backshell for heatshrink sleeving <b>32</b> - backshell for shield termination and heatshrink sleeving <b>09</b> - receptacle 00 or 07 with PC tail contacts size 20 $\varnothing$ 0.60 mm - length 7.30 mm Max.



# 8526 Series

## Hermetic connectors

<b>basic series</b>	<b>8526</b>	<b>2</b>	<b>H</b>	<b>1006</b>	<b>P</b>	<b>N</b>
<b>shell type</b>	<ul style="list-style-type: none"> <li>1 - solder fixing receptacle</li> <li>2 - square flange receptacle</li> <li>7 - jam nut receptacle</li> </ul>					
<b>plating</b>	H - tin over nickel					
<b>contact layout</b>	- see table p 50					
<b>contact type</b>	P - male contact only					
<b>orientation</b>	<ul style="list-style-type: none"> <li>N - normal</li> <li>W, X, Y, Z - see table p 51</li> </ul>					

## Backshells

<b>basic series</b>	<b>852</b>	<b>-</b>	<b>01</b>	<b>G</b>	<b>10</b>
<b>backshell type</b>	<ul style="list-style-type: none"> <li>01 - backnut</li> <li>02 - straight cable clamp</li> <li>03 - elbow cable clamp</li> <li>17 - backshell for heatshrink sleeving</li> <li>32 - backshell for shield termination and heatshrink sleeving</li> </ul>				
<b>plating</b>	<ul style="list-style-type: none"> <li>G - olive green cadmium</li> <li>N - nickel</li> </ul>				
<b>shell size</b>	08-10-12-14-16-18-20-22-24				

## Caps

<b>basic series</b>	<b>852</b>	<b>27</b>	<b>G</b>	<b>10</b>	<b>..</b>
<b>caps type</b>	<ul style="list-style-type: none"> <li>26 - cap for plug</li> <li>27 - cap for square flange receptacle</li> <li>28 - cap for plug</li> <li>29 - cap for jam nut receptacle</li> </ul>				
<b>plating</b>	<ul style="list-style-type: none"> <li>G - olive green cadmium</li> <li>N - nickel</li> </ul>				
<b>shell size</b>	08-10-12-14-16-18-20-22-24				
<b>specification</b>	<ul style="list-style-type: none"> <li>- metallic chain : without digit</li> <li>26 - nylon cord</li> </ul>				



# 8526 Series

## Cross reference list

Souriau	NFC 93422 HE 312	Designation
8526-00 G .. B .. P S	HE 312 0E .... P 7 S	square flange receptacle olive green plating
8526-00 N .. B .. P S	HE 312 0E .... P 6 S	square flange receptacle nickel plating
8526-07 G .. B .. P S	HE 312 7E .... P 7 S	jam nut receptacle olive green plating
8526-07 N .. B .. P S	HE 312 7E .... P 6 S	jam nut receptacle nickel plating
8526-16 G .. B .. P S	HE 312 6E .... P 7 S	plug olive green plating
8526-16 N .. B .. P S	HE 312 6E .... P 6 S	plug nickel plating
8526-36 G .. B .. P S	HE 312 5E .... P 7 S	RFI shielded plug olive green plating
8526-36 N .. B .. P S	HE 312 5E .... P 6 S	RFI shielded plug nickel plating
8526-1H .... P	HE 312 1H .... P 2	solder flange receptacle
8526-2H .... P	HE 312 2H .... P 2	square flange receptacle
8526-7H .... P	HE 312 7H .... P 2	jam nut receptacle
852 - 01 G ..	HE 312 01 - .. - 7	backnut olive green plating
852 - 01 N ..	HE 312 01 - .. - 6	backnut nickel plating
852 - 02 G ..	HE 312 02 - .. - 7	straight cable clamp olive green plating
852 - 02 N ..	HE 312 02 - .. - 6	straight cable clamp nickel plating
852 - 03 G ..	HE 312 03 - .. - 7	elbow cable clamp olive green plating
852 - 03 N ..	HE 312 03 - .. - 6	elbow cable clamp nickel plating
852 - 32 G ..	HE 312 06 - .. - 7	backshell for screen termination and heatshrink sleeving olive green plating
852 - 32 N ..	HE 312 06 - .. - 6	backshell for screen termination and heatshrink sleeving nickel plating
852 - 26 G ..	HE 312 B06 - .. - 7	cap for plug olive green plating, metallic chain, ring
852 - 26 N ..	HE 312 B06 - .. - 6	cap for plug nickel plating, metallic chain, ring
852 - 27 G ..	HE 312 B00 - .. - 7	cap for receptacle olive green cadmium, metallic chain, eyelet
852 - 27 N ..	HE 312 B00 - .. - 6	cap for receptacle nickel plating metallic chain, eyelet
852 - 28 G ..	HE 312 B16 - .. - 7	cap for plug olive green cadmium, metallic chain, eyelet
852 - 28 N ..	HE 312 B16 - .. - 6	cap for plug nickel plating, metallic chain, eyelet
852 - 29 G ..	HE 312 B07 - .. - 7	cap for receptacle olive green cadmium, metallic chain, ring
852 - 29 N ..	HE 312 B07 - .. - 6	cap for receptacle nickel plating metallic chain, ring
8522 - 20	NF L 54•131 - 20	plastic tool for size 20 contacts
8522 - 16	NF L 54•131 - 16	plastic tool for size 16 contacts
8522 - 12	NF L 54•131 - 12	plastic tool for size 12 conta



# 8526 Series

## Contact layouts viewed from front face of male insulator

shells								
08	10	12	14	16	18	20	22	24
8 B 3A 8 B 98 *08 3A	10 B 6 *10 06	12 B 10 *12 10	14 B 19 *14 19	16 B 26 *16 26	18 B 32 *18 32	20 B 41 *20 41	22 B 55 *22 55	24 B 61 *24 61
3Ø1	6Ø1	10Ø1	19Ø1	26Ø1	32Ø1	41Ø1	55Ø1	61Ø1
8 B 33 *08 33	SN 0394	12 B 3 *12 03	14 B 15 *14 15	16 B 8 *16 08	18 B 11	20 B 39 *20 39	22 B 41 *22 41	24 B 31
3Ø1	1 coax	3Ø1.6	14Ø1 1Ø1.6	8Ø1.6	11Ø1.6	37Ø1 2Ø1.6	27Ø1 14Ø1.6	31Ø1.6
		12 B 8	14 B 12 *14 12	16 B 23	18 B 8 *18 8	20 B 16 *20 16	22 B 21 *22 21	24 B 19
		8Ø1	8Ø1 4Ø1.6	22Ø1 1Ø1.6	8Ø2.4	16Ø1.6	21Ø1.6	19Ø2.4
		14 B 5 *14 05			SN 0468		22 B 12	SN 1229
		8Ø1 5Ø1.6			2Ø2.04 2Ø1		12Ø2.4	52Ø1 2 coax # 12
		14 B 4 *14 4						SN 0797
		4Ø2.4						58Ø1 1 Coax 50 Ω

\* hermetic receptacle available  
 Specials SHTP



# 8526 Series

## Polarization

(insulator rotated inside metal body)

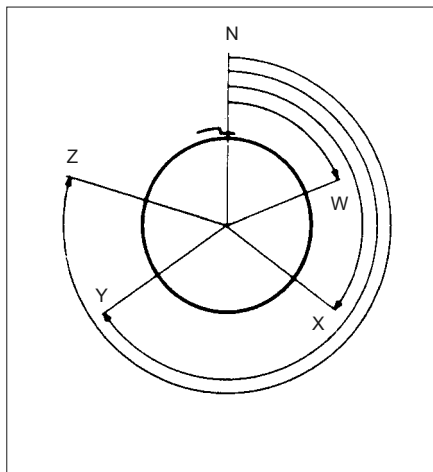

shell size	layouts	service I 1500 Vrms	service II 2300 Vrms	number of contacts			angles in degrees				
				size 20	size 16	size 12	N	W	X	Y	Z
08	0 8 3 A	X		3			0	60	210	-	-
	0 8 3 3	X		3			0	90	-	-	-
	0 8 9 8	X		3			0	-	-	-	-
10	1 0 0 6	X		6			0	90	-	-	-
12	1 2 1 0	X		10			0	60	155	270	295
	1 2 0 3		X		3		0	-	-	180	-
	1 2 8	X		8			0	90	112	203	292
14	1 4 1 9	X		19			0	30	165	315	-
	1 4 1 5	X		14	1		0	17	110	155	234
	1 4 1 2	X		8	4		0	43	90	-	-
	1 4 0 5		X		5		0	40	92	184	273
	1 4 0 4	X				4	0	45	-	-	-
16	1 6 2 6	X		26			0	60	-	275	338
	1 6 0 8		X		8		0	54	152	180	331
	1 6 2 3	X		22	1		0	158	270	-	-
	1 8 3 2	X		32			0	85	138	222	265
18	1 8 1 1		X		11		0	62	119	241	340
	1 8 0 8	X				8	0	180	-	-	-
20	2 0 4 1	X		41			0	45	126	225	-
	2 0 3 9	X		37	2		0	63	144	252	333
	2 0 1 6		X		16		0	238	318	333	347
22	2 2 5 5	X		55			0	30	142	226	314
	2 2 4 1	X		27	14		0	39	135	264	-
	2 2 2 1		X		21		0	16	135	175	349
	2 2 1 2	X				12	0	-	-	-	-
24	2 4 6 1	X		61			0	90	180	270	324
	2 4 3 1	X			31		0	90	225	255	-
	2 4 1 9		X			19	0	30	165	315	-

## Contacts

contact size	# 20 standard	# 20*	# 16 standard	# 16*	# 12 standard
--------------	---------------	-------	---------------	-------	---------------

## Technical characteristics

diameter	1 mm	1 mm	1,6 mm	1,6 mm	2,4 mm
retention force	90 N	90 N	115 N	115 N	136 N
current rating	7,5 A	7,5 A	13 A	13 A	23 A
contact resistance	≤ 1 mΩ	≤ 1 mΩ	≤ 0,55 mΩ	≤ 0,55 mΩ	≤ 0,35 mΩ

## Admissible wires

external Ø over insulator	0,98 to 2,11 mm	0,98 to 2,11 mm	1,34 to 2,62 mm	1,34 to 2,62 mm	2,45 to 4,01 mm
admissible section	0,21 to 0,60 mm <sup>2</sup>	0,21 to 0,93 mm <sup>2</sup>	0,60 to 1,34 mm <sup>2</sup>	0,93 to 1,91 mm <sup>2</sup>	1,91 to 3,18 mm <sup>2</sup>
wire gauge	24 to 20	24 to 18	20 to 16	18 to 14	14 to 12
reducing sleeve for wire of	0,09 to 0,21 mm <sup>2</sup>	-	-	-	A

## Part numbers

male contact	8526-1348	8522-2349 A	8526-1349	8522-6179 A	8526-1350
female contact	8526-1344	8520-292	8526-1346	8522-6180 A	8526-1347
colour code	red-red	red-violet	blue-blue	blue-orange	yellow-yellow
male contact thermocouples - chromel color code	8522-875 yellow	8522-3761 yellow	8522-881 yellow	-	8522-887 yellow
thermocouples - alumel color code	8522-876 black	8522-3760 black	8522-882 black	-	8522-888 black
female contact thermocouples - chromel color code	8522-877 yellow	8522-3770 yellow	8522-883 yellow	-	8522-889 yellow
thermocouples - alumel color code	8522-878 black	8522-3771 black	8522-884 black	-	8522-890 black
reducing sleeve	8522-2142	-	-	-	-

## Minicoax contacts

minicoax installed instead of size 16 contacts

male contacts	8526-2-001 A	8526-2-002 A	8526-2-003 A
female contacts	8526-1-001 A	8526-1-002 A	8526-1-003 A
cables accepted	RG-174 U/KX 3 A RG-316 U/KX 22 A	RG-178 BU/KX 21 A	RG 179 BU

minicoax installed instead of size 12 contacts

male contacts	8526-12-2-001	8526-12-2-002	8526-12-2-003	8526-12-2-004
female contacts	8526-12-1-001	8526-12-1-002	8526-12-1-003	8526-12-1-004
cables accepted	RG 178 BU	RG 179 BU	RG 316 U	RG 180 BU



# 8526 Series

## Dimensions

### 16 and 36 plug type

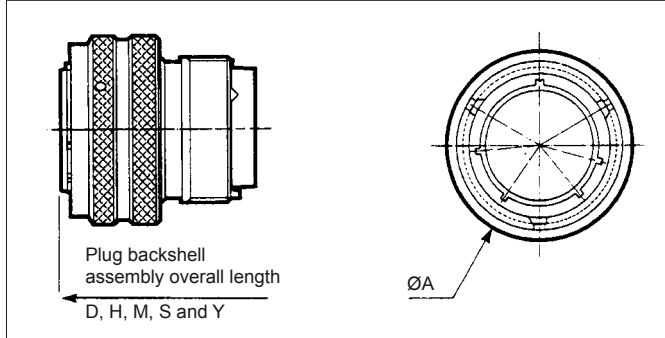

shell size	A	B Max	C	D Max	E min	E Max	F Max	G Max	H Max
08	18.95 .746	15.65 .616	6.75 .266	36.5 1.437	4 .157	5.85 .230	19.1 .752	22.25 .876	46.5 1.831
10	22.65 .892	18.6 .732	9.4 .370	36.5 1.437	6.85 .270	8.7 .343	20.3 .799	22.25 .876	46.5 1.831
12	25.75 1.014	21.75 .856	12.8 .504	36.5 1.437	10.15 .856	12 .504	23.5 1.437	22.25 .400	46.5 .472
14	29.75 1.171	24.95 .982	14.75 .581	36.5 1.437	11.7 .461	16.75 .659	25.5 1.004	27.45 1.081	51.8 2.039
16	32.95 1.297	28.2 1.110	17.93 .706	36.5 1.437	15.5 .610	20.55 .809	29.5 1.161	27.45 1.081	51.8 2.039
18	35.35 1.392	30.9 1.217	19.94 .785	36.5 1.437	17.5 .689	22.55 .888	32.3 1.272	27.45 1.081	51.8 2.039
20	38.75 1.526	34.15 1.344	23.11 .910	36.5 1.437	20.7 .815	25.75 1.014	36 1.417	27.45 1.081	51.8 2.039
22	41.85 1.648	37.25 1.467	26.29 1.035	36.5 1.437	23.9 .941	28.95 1.140	39 1.535	27.45 1.081	51.8 2.039
24	45.05 1.774	40.45 1.593	29.2 1.150	36.5 1.437	27 1.063	32.05 1.262	42.7 1.681	27.45 1.081	51.8 2.039

### Backshells

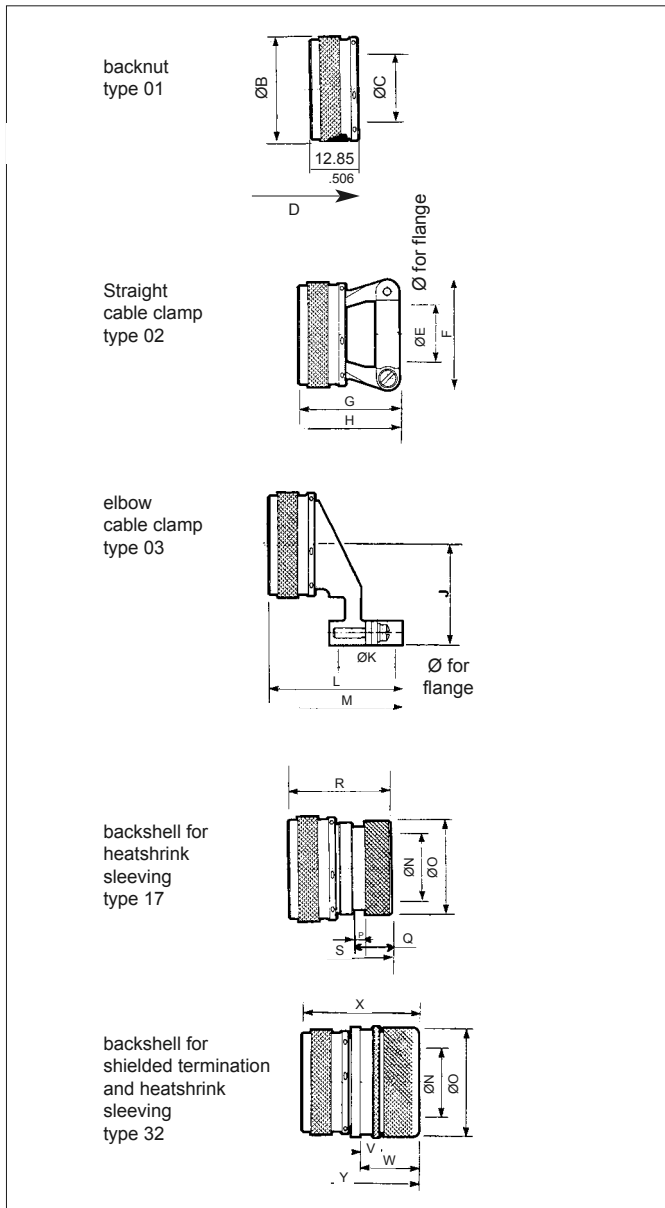

shell size	J Max	K min	K Max	L Max	M Max	N min	O Max	P	Q Max
08	20 .787	4 .157	5.85 .230	25 .984	49.3 1.941	6.75 .266	13.5 .531	3.3 .130	10.6 .417
10	22.2 .874	6.85 .270	8.7 .343	27.9 1.098	52.2 2.055	9.4 .370	15.35 .604	3.3 .130	10.6 .417
12	24 .945	10.15 .400	12 .472	31.2 1.228	55.5 2.185	12.8 .504	19.65 .774	3.3 .130	10.6 .417
14	24.5 .965	11.7 .461	16.75 .659	32.8 1.291	57.1 2.248	14.75 .581	21.25 .837	3.3 .130	10.6 .417
16	27 1.063	15.5 .610	20.55 .809	36.5 1.437	61 2.402	17.93 .706	24.45 .963	3.3 .130	10.6 .417
18	28.6 1.126	17.5 .689	22.55 .888	38.5 1.516	63 2.480	17.93 .785	24.45 1.041	3.3 .130	10.6 .417
20	30.1 1.185	20.7 .815	25.75 1.014	41.8 1.646	66.2 2.606	23.11 .910	30.9 1.217	3.3 .130	10.6 .417
22	31.9 1.256	23.9 .941	28.95 1.140	45 1.772	69.3 2.728	26.29 1.035	34.4 1.354	3.3 .130	10.6 .417
24	33.4 1.315	27 1.063	32.05 1.262	48 1.890	72.3 2.846	29.2 1.150	36.65 1.443	3.3 .130	10.6 .417

shell size	R Max	S Max	T Max	U Max	V	W Max	X Max	Y Max
08	28.55 1.124	52 2.047	7.5 .295	18.2 .717	3.5 .138	15 .591	29 1.142	53.3 2.098
10	28.55 1.124	52 2.047	9.7 .382	19.2 .756	3.5 .138	15 .591	29 1.142	53.3 2.098
12	28.55 1.124	52 2.047	13 .512	24.2 .953	3.5 .138	15 .591	29 1.142	53.3 2.098
14	28.55 1.124	52 2.047	15 .591	27.2 1.071	3.5 .138	15 .591	29 1.142	53.3 2.098
16	28.55 1.124	52 2.047	18.3 .720	30.2 1.189	3.5 .138	15 .591	29 1.142	53.3 2.098
18	28.55 1.124	52 2.047	21 .827	33.2 1.307	3.5 .138	15 .591	29.3 1.154	53.6 2.110
20	28.55 1.124	52 2.047	23.5 .925	36.3 1.429	3.5 .138	15 .591	29.3 1.154	53.6 2.110
22	28.55 1.124	52 2.047	26.5 1.043	39.5 1.555	3.5 .138	15 .591	29.3 1.154	53.6 2.110
24	28.55 1.124	52 2.047	30 1.181	42.6 1.677	3.5 .138	15 .591	29.3 1.154	53.6 2.110



# 8526 Series

## Environmental square flange receptacle - 00 type

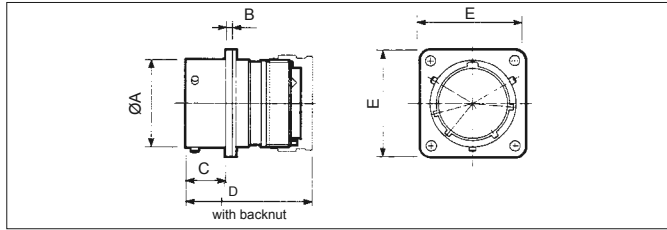

panel cut-out

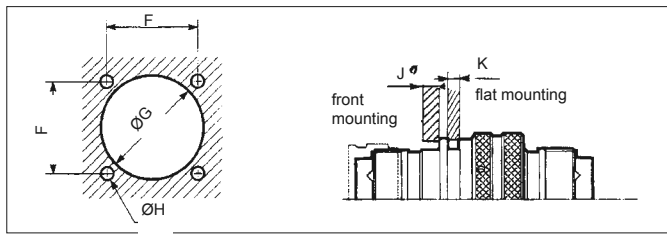

shell size	A Max	B Max	C Max	D Max	E Max	F	G	H	J Max	K Max
08	12.03 .474	1.95 .077	11.7 .461	36.5 1.437	21 .827	15.09 .594	14.43 .568	3.05 .120	3.17 .125	2.21 .087
10	15.01 .591	1.95 .077	11.7 .461	36.5 1.437	24.2 .953	18.26 .719	17.4 .685	3.05 .120	3.17 .125	2.21 .087
12	19.07 .751	1.95 .077	11.7 .461	36.5 1.437	26.55 1.045	20.62 .812	21.95 .864	3.05 .120	3.17 .125	2.21 .087
14	22.25 .876	1.95 .077	11.7 .461	36.5 1.437	28.9 1.138	23.01 .906	25.12 .989	3.05 .120	3.17 .125	2.21 .087
16	25.42 1.001	1.95 .077	11.7 .461	36.5 1.437	31.3 1.232	24.61 .969	28.27 1.113	3.05 .120	3.17 .125	2.21 .087
18	28.6 1.126	1.95 .077	11.7 .461	36.5 1.437	33.7 1.327	26.97 1.062	31.45 1.238	3.05 .120	3.17 .125	2.21 .087
20	31.77 1.251	2.75 .108	14.35 .565	38.1 1.500	36.9 1.453	29.36 1.156	34.62 1.363	3.05 .120	3.17 .125	5.38 .212
22	34.95 1.376	2.75 .108	14.35 .565	38.1 1.500	40 1.575	31.75 1.250	37.8 1.488	3.05 .120	3.17 .125	5.38 .212
24	38.12 1.501	2.75 .108	15.2 .598	38.1 1.500	43.3 1.705	34.92 1.375	41.02 1.615	3.73 .147	3.17 .125	5.38 .212

## Environmental jam nut receptacle - 07 type

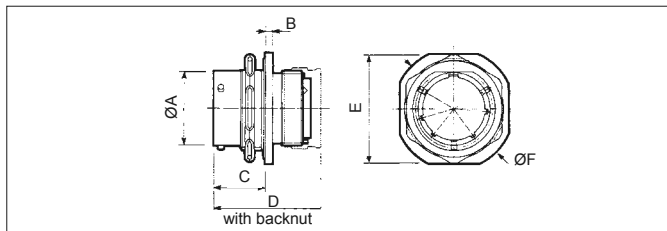

panel cut-out

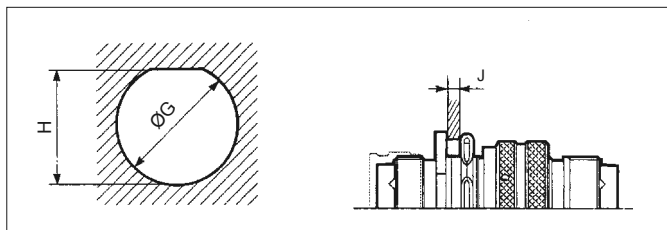

shell size	A Max	B Max	C Max	D Max	E Max	F Max	G	H	J Max
08	12.03 .474	2.51 .099	17.55 .691	36.5 1.437	24.05 .947	27.2 1.071	14.53 .572	13.61 .536	4.75 .187
10	15.01 .591	2.51 .099	17.55 .691	36.5 1.437	27.2 1.071	30.4 1.197	17.7 .697	16.79 .661	4.75 .187
12	19.07 .751	2.51 .099	17.55 .691	36.5 1.437	32 1.260	35.15 1.384	22.73 .895	20.93 .824	4.75 .187
14	22.25 .876	2.51 .099	17.55 .691	36.5 1.437	35.15 1.384	38.35 1.510	25.65 1.010	24.08 .948	4.75 .187
16	25.42 1.001	2.51 .099	17.55 .691	36.5 1.437	38.35 1.510	41.5 1.634	28.83 1.135	27.23 1.072	4.75 .187
18	28.6 1.126	2.51 .099	17.55 .691	36.5 1.437	41.5 1.634	44.7 1.760	32 1.260	30.4 1.197	4.75 .187
20	31.77 1.251	3.3 .130	19.15 .754	38.1 1.500	46.25 1.821	49.45 1.947	35.18 1.385	33.58 1.322	6.35 .250
22	34.95 1.376	3.3 .130	19.15 .754	38.1 1.500	49.45 1.947	52.6 2.071	38.35 1.510	36.75 1.447	6.35 .250
24	38.12 1.501	3.3 .130	19.15 .754	38.1 1.500	52.6 2.071	55.8 2.197	41.53 1.635	39.93 1.572	5.55 .219

## Solder fixing receptacle - 2 H type

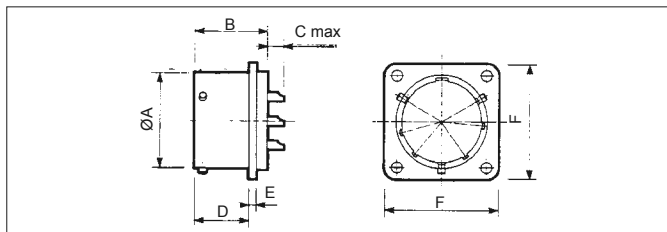

panel cut-out

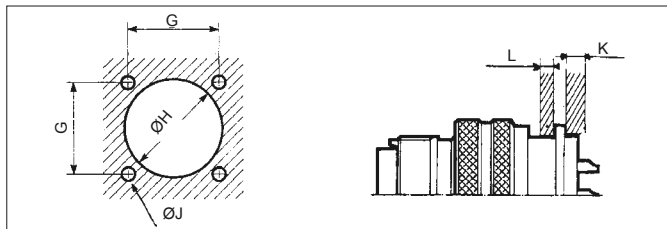

shell size	A Max	B Max	C # 20 # 16	D Max	E Max	F Max	G	H	J	K Max	L Max
08	12.05 .474	19.8 .780	4.5 .177	15.05 .593	1.95 .077	21 .827	15.1 .594	15.55 .612	3.15 .124	3.2 .126	3 .118
10	15 .591	19.8 .780	4.5 .177	15.05 .593	1.95 .077	24.2 .953	18.26 .719	18.8 .740	3.15 .124	3.2 .126	3 .118
12	19.05 .750	19.8 .780	4.5 .177	6.3 .248	15.05 .593	1.95 .077	26.55 1.045	20.62 .812	22.15 .872	3.15 .124	3 .118
14	22.25 .876	19.8 .780	4.5 .177	6.3 .248	15.05 .593	1.95 .077	28.95 1.140	23.01 .906	25.3 .996	3.15 .124	3 .118
16	25.4 1.000	19.8 .780	4.5 .177	6.3 .248	15.05 .593	1.95 .077	31.3 1.232	24.61 .969	28.45 1.120	3.15 .124	3 .118
18	28.6 1.126	19.8 .780	4.5 .177	6.3 .248	15.05 .593	1.95 .077	33.7 1.327	26.97 1.062	31.65 1.246	3.15 .124	3 .118
20	31.75 1.250	20.95 .825	4.6 .181	6.3 .248	16.6 .654	2.4 .094	36.9 1.453	29.36 1.156	34.8 1.370	3.15 .124	5.4 .213
22	34.95 1.376	21.8 .858	3.7 .146	5.55 .219	16.6 .654	2.4 .094	40.1 1.579	31.75 1.250	38 1.496	3.15 .124	5.4 .213
24	38.1 1.500	21.8 .858	3.7 .146	5.55 .219	16.6 .654	2.4 .094	43.25 1.703	34.92 1.375	41.2 1.622	3.3 .130	5.4 .213



# 8526 Series

## Jam nut receptacle - 7 H type

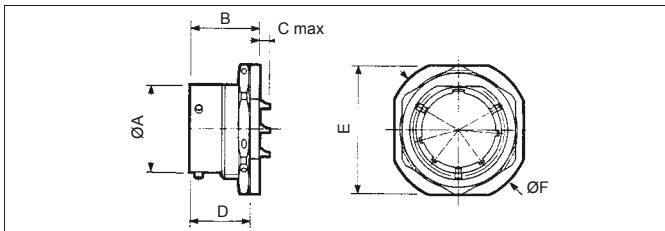

### panel cut-out

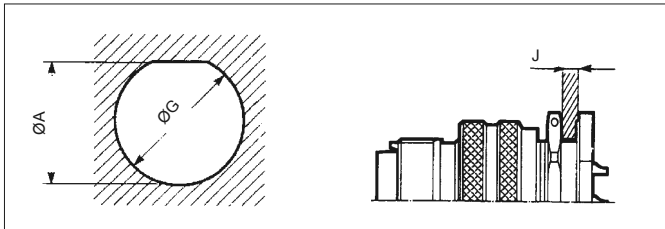

shell size	A	B	C		D	E	F	G	H	J	
	Max	Max	# 20	# 12 # 16	Max	Max	Max			min	Max
08	12.05 .474	20.73 .816	3.4 .134	—	17.95 .707	24.2 .953	27.34 1.076	14.6 .575	13.75 .541	1.57 .062	4.75 .187
10	15 .591	20.73 .816	3.4 .134	—	17.95 .707	27.34 1.076	30.52 1.202	17.75 .699	16.95 .667	1.57 .062	4.75 .187
12	19.05 .750	20.73 .816	3.4 .134	5.2 205	17.95 .707	32.12 1.265	35.29 1.389	22.5 .886	21.5 .846	1.57 .062	4.75 .187
14	22.25 .876	20.73 .816	3.4 .134	5.2 205	17.95 .707	35.29 1.389	38.47 1.515	25.7 1.012	24.2 .963	1.57 .062	4.75 .187
16	25.4 1.000	20.73 .816	3.4 .134	5.2 205	17.95 .707	38.47 1.515	41.64 1.639	28.85 1.136	27.35 1.077	1.57 .062	4.75 .187
18	28.6 1.126	20.73 .816	3.4 .134	5.2 205	17.95 .707	41.64 1.639	44.82 1.765	32.05 1.262	30.55 1.203	1.57 .062	4.75 .187
20	31.75 1.250	23.08 .909	2.8 .110	4.5 .177	19.5 .768	46.39 1.826	49.59 1.952	35.2 1.386	33.7 1.327	1.57 .062	6.35 .250
22	34.95 1.376	23.08 .909	2.8 .110	4.5 .177	19.5 .768	49.59 1.952	52.74 2.076	38.4 1.512	36.9 1.453	1.57 .062	6.35 .250
24	38.1 1.500	23.83 .938	2 .079	3.8 .150	20.15 .793	52.74 2.076	55.92 2.202	41.55 1.636	40.05 1.577	1.57 .062	5.55 .219

## Hermetic solder fixing receptacle - 1 H type

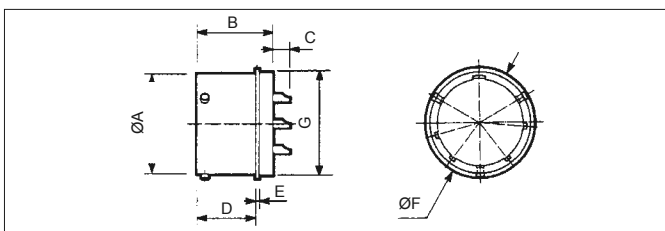

### panel cut-out

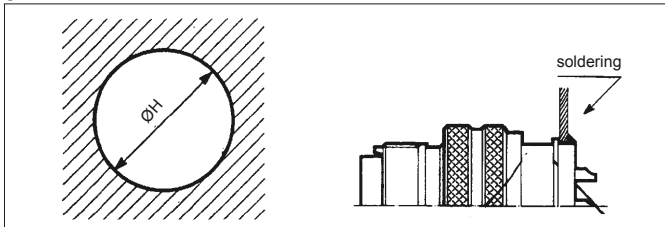

shell size	A	B	C		D	E	F	G	H
	Max	Max	# 20	# 12 # 16	Max	Max	Max	Max	
08	12.05 .474	19.5 .768	4.5 .177	—	15.1 .594	1.1 .043	16.1 .634	14.27 .562	14.48 .570
10	15 .591	19.5 .768	4.5 .177	—	15.1 .594	1.1 .043	19.3 .760	17.06 .672	17.27 .680
12	19.05 .750	19.5 .768	4.5 .177	6.3 .248	15.1 .594	1.1 .043	21.65 .852	19.83 .781	20.04 .789
14	22.25 .876	19.5 .768	4.5 .177	6.3 .248	15.1 .594	1.1 .043	24.85 .978	23.01 .906	23.22 .914
16	25.4 1.000	19.5 .768	4.5 .177	6.3 .248	15.1 .594	1.1 .043	28 1.102	26.18 1.031	26.39 1.039
18	28.6 1.126	19.5 .768	4.5 .177	6.3 .248	15.1 .594	1.1 .043	31.15 1.226	29.36 1.156	29.57 1.164
20	31.75 1.250	21.1 .831	4.5 .177	6.3 .248	16.7 .657	1.1 .043	33.55 1.321	31.74 1.250	31.95 1.258
22	34.95 1.376	22 .866	3.7 .146	5.5 .217	16.7 .657	1.1 .043	36.75 1.447	34.92 1.375	35.13 1.383
24	38.1 1.500	22 .866	3.7 .146	5.5 .217	16.7 .657	1.1 .043	39.95 1.573	38.09 1.500	38.3 1.508

## Caps

<b>basic series</b>		<b>852</b>	<b>27</b>	<b>G</b>	<b>10</b>	<b>••</b>
<b>caps type</b>	<ul style="list-style-type: none"> <li>26 - cap for plug (plug fixing)</li> <li>27 - cap for square flange receptacle</li> <li>28 - cap for plug (backshell fixing)</li> <li>29 - cap for jam nut receptacle</li> </ul>					
<b>plating</b>	<ul style="list-style-type: none"> <li>G - olive green cadmium</li> <li>N - nickel</li> </ul>					
<b>shell size</b>	<b>08-10-12-14-16-18-20-22-24</b>					
<b>specification</b>	<ul style="list-style-type: none"> <li>- metallic chain : without digit</li> <li>26 - nylon cord</li> </ul>					



# 8526 Series

## Caps

### Caps for plug

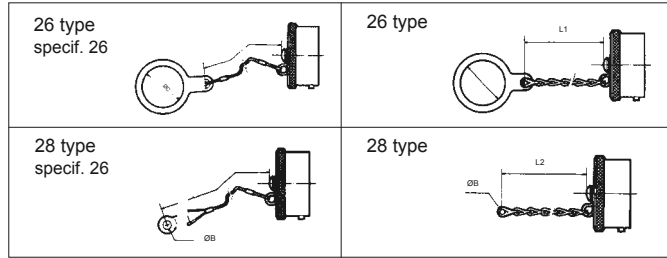

### Caps for receptacle

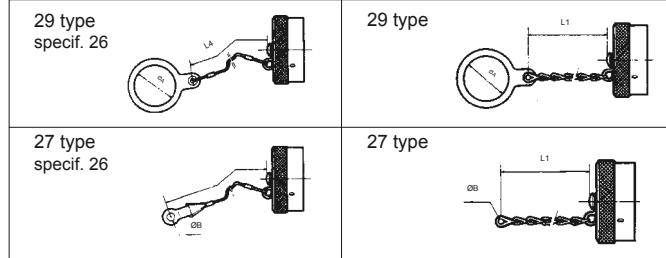

shell size	A Max	B Max	C Max	L1	L2	L3	L4
08	14.8 .583	3.5 .138	14.8 .583	84 3.307	132 5.197	128 5.039	80 3.150
10	17.9 .705	3.5 .138	17.9 .705	84 3.307	132 5.197	128 5.039	80 3.150
12	22.7 .894	3.5 .138	22.7 .894	100 3.937	148 5.827	140 5.512	90 3.543
14	25.9 1.020	3.5 .138	25.9 1.020	100 3.937	148 5.827	140 5.512	90 3.543
16	29 1.142	3.5 .138	29 1.142	10 3.937	148 5.827	140 5.512	90 3.543
18	32.2 1.268	3.5 .138	32.2 1.268	100 3.937	148 5.827	140 5.512	90 3.543
20	35.4 1.394	3.5 .138	35.4 1.394	116 4.567	168 6.614	153 6.024	110 4.331
22	38.6 1.520	3.5 .138	38.6 1.520	116 4.567	168 6.614	153 6.024	110 4.331
24	41.7 1.642	3.5 .138	41.7 1.642	116 4.567	168 6.614	153 6.024	110 4.331

## Panel gaskets

shell size	part numbers	
	gaskets square flange receptacle	o ring - jam nut receptacle 07 and 7 H type
08	8525-1431	70617A
10	8525-1432	70618A
12	8525-1433	70619A
14	8525-1434	70620A
16	8525-1435	70621A
18	8525-1436	70622A
20	8525-1437	70623A
22	8525-1438	70624A
24	8525-1439	70625A

## Dummy receptacle

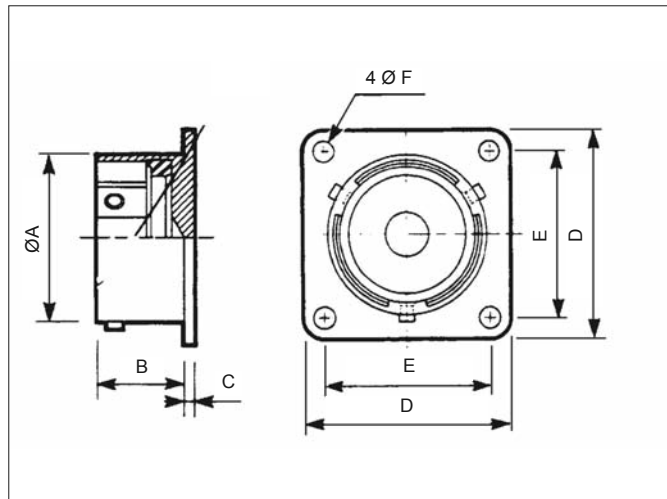

shell size	part number		A Max	B Max	C	D Max	E	F
	Olive green	nickel						
08	8526-0708	8526-07N08	12.03 .474	11.7 .461	1.35 .053	21 .827	15.09 .594	3.1 .122
10	8526-0710	8526-07N10	15.01 .591	11.7 .461	1.35 .053	24.2 .953	18.26 .719	3.1 .122
12	8526-0712	8526-07N12	19.07 .751	11.7 .461	1.35 .053	26.55 1.045	20.62 .812	3.1 .122
14	8526-0714	8526-07N14	22.25 .876	11.7 .461	1.35 .053	29 1.142	23.01 .906	3.1 .122
16	8526-0716	8526-07N16	25.42 1.001	11.7 .461	1.35 .053	31.3 1.232	24.61 .969	3.1 .122
18	8526-0718	8526-07N18	28.6 1.126	11.7 .461	1.35 .053	33.7 1.327	26.97 1.062	3.1 .122
20	8526-0720	8526-07N20	31.77 1.251	14.35 .565	2.15 .085	36.9 1.453	29.36 1.156	3.1 .122
22	8526-0722	8526-07N22	34.95 1.376	14.35 .565	2.15 .085	40 1.575	31.75 1.250	3.1 .122
24	8526-0724	8526-07N24	38.12 1.501	15.2 .598	2.15 .085	43.3 1.705	34.92 1.375	3.75 .148

## Reusable fixing plates

Two, three or four holes self locking fixing plates are available at SHTP. See page 743