



# 8622 NAFI 2

## Applications

Military airborne computer.

## Standards

## Characteristics

### Mechanical

- Contact insertion force per contact pair :
  - signal contacts (average) : 0.46 N
  - AWG 16 power contacts (Max) : 6.70 N
- Compliant pin retention in Pwb PTH : 25 N
- Contact life :
  - mating/unmating cycles : 500
- Minimum shortest blade contact security : 1.39 mm

### Electrical

- Signal contact maximum current rating :
  - permanent : 1 A
  - during 3600 seconds : 2 A
  - during 40 seconds : 3 A
- Power contact maximum current rating :
  - permanent : 13 A
- Dielectric withstanding voltage
  - at sea level : 600 VAC
  - at an altitude of 13700 meters : 250 VAC
- Insulation resistance : 1000 MΩ
- Capacitance between contacts at 10 MHz
- With flex-cable termination : 3.5 pF
- Contact resistance Max (mated) : 30 mΩ



### Physical

#### As per CEI 512

- Damp heat at 40°C/94% R.H (mated) : 56 days
- Thermal shocks (-55°C to +125°C) : 5 cycles
- Salt spray 5% NaCl/35°C : 48 hrs
- Physical shocks in 3 directions
  - 1/2 sine-6ms : 100 g
- Vibrations : (no discontinuity)
  - sine 10 - 2000 Hz - 15g/150 mn/axis Satisfact.
  - random 50 - 2000 Hz - 20g - 0.2g/Hz - 15 mn Satisfact.
- Working temperature -55°C to + 125°C Satisfact.
- Temperature ageing (1000 hrs) 125°C
- Resistance at areo fluids (EN2591 a.p.C15) Satisfact.
- Weight in grams (396 way pair) 50grs

### Materials and finishes

components	materials	finishes
modular insulators	black PPS UL94 VO autoextinguish.	
contacts flex cable extruded supports	copper alloy polyimid ana copper aluminum alloy	a.p.MIL black anodized
male polarizing pins female polarizing keys	stainless steel aluminum alloy	

## Description

- The NAFI 2 Series is a modular connector, available either with 8 or 4 rows of contacts, offering a very large diversity in the contact number selection, from 16 up to 556 ways. The connectors use improved miniaturized tuning-forks and blade-contacts derived from the MIL-C 28754 standard.
- One of the most interesting aspect of the new 8622 Series is the press-fit field proven technology. It provides a very low profile female connector and contributes reducing the volume and weight of the equipment and making easier backplane repair.
- The male header is available with SMT one-piece contact and flex-cable as well; both terminations are interchangeable on the daughter board. Male and female connectors are available also with straight solder PC tail or press fitted terminations for parallel cards dispositions.
- The insulator modules are provided with closed entry cavities for tuning-fork contact protection during mating operation. Both female end modules are fitted with standard signal contact and polarizing keys. The end modules are also available with AWG 16 cavities for power, coaxial or fiber optic of the MIL-C 38999 Series II crimp contacts.

## Ordering information

<b>basic series</b>	<b>8622</b>	<b>M</b>	<b>396</b>	<b>-</b>	<b>8</b>	<b>07</b>	<b>000</b>
<b>connector type</b>	<b>M</b> - male <b>F</b> - female						
<b>number of contacts</b>	see next page						
<b>mandatory separation dot</b>							
<b>number of rows</b>	<b>- 8 or 4</b>						
<b>contact termination style</b>	<b>07</b> - SMT one-piece contact <b>14</b> - straight solder spills <b>82</b> - press-fit						
<b>suffix</b>	<b>000</b> - standard <b>XXX</b> - any particular specification						

**Remark** : Above part-numbering system is given as an information.

Described example : 8622 M396-807000 is a 396 way 8 row standard male header with SMT terminations.

For any particular design, you are requested to compose your reference and consult us for getting a definitive part number and customer drawings as well.



# 8622 NAFI 2

## The 8622 range

card format							connector			8 row connector (15.24 mm pitch between cards)		4 row connector (10.16 mm between cards)		
dimension	A1 / B1 SEM	single Europe	SEME	half ATR	A3 / B3 SEM	double Europe	number of fixings	number of modules	overall dimension	number of contacts				
										8 rows populated	6 rows populated	4 rows populated	2 rows populated	
69.90 2.752								2	36.60 1.441	76	56	36	16	
									49.30 1.941	116	86	56	26	
									62.00 2.441	156	116	76	36	
100.00 3.937							2	74.70 2.941	196	146	96	46		
								87.40 3.441	236	176	116	56		
149.30 5.878									100.10 3.941	276	206	136	66	
									112.80 4.441	316	236	156	76	
									125.50 4.941	356	266	176	86	
									138.20 5.441	396	296	196	96	
164.00 6.457									11	159.80 6.291	436	326	216	106
222.00 8.740								3	172.50 6.791	476	356	236	116	
									185.20 7.291	516	386	256	126	
233.00 9.173									14	197.90 7.791	556	416	276	136

The 8622 connector series covers a large range of card formats, from the smallest SEM A1/B1 up to the 233 mm long DOUBLE EUROPE style. In accordance with the number of modules, the above table shows the overall dimensions of the connector. The shortest connector is composed of at least 2 modules. The longest, fitted with 14 modules, offers 556 contacts in a 197.90 mm length only. From 2 to 10 modules, the male header is fastened on to the daughter card by 2 fixing points. Over 10 modules, a third center fixing is necessary.

Above table displays the connector flexibility. As an example, the connector ranges from 76 to 556 contacts for 8 row cavities totally equipped with their contacts. The same 8 row modules may be underloaded in 6 rows only. In that case, the connector ranges from 56 to 416 contacts. On the same way, a 4 row module connector fully equipped offers 36 to 276 contacts and only 16 to 136 as partially populated.



# 8622 NAFI 2

## Male header dimensions

### 4 row connector with SMT terminations

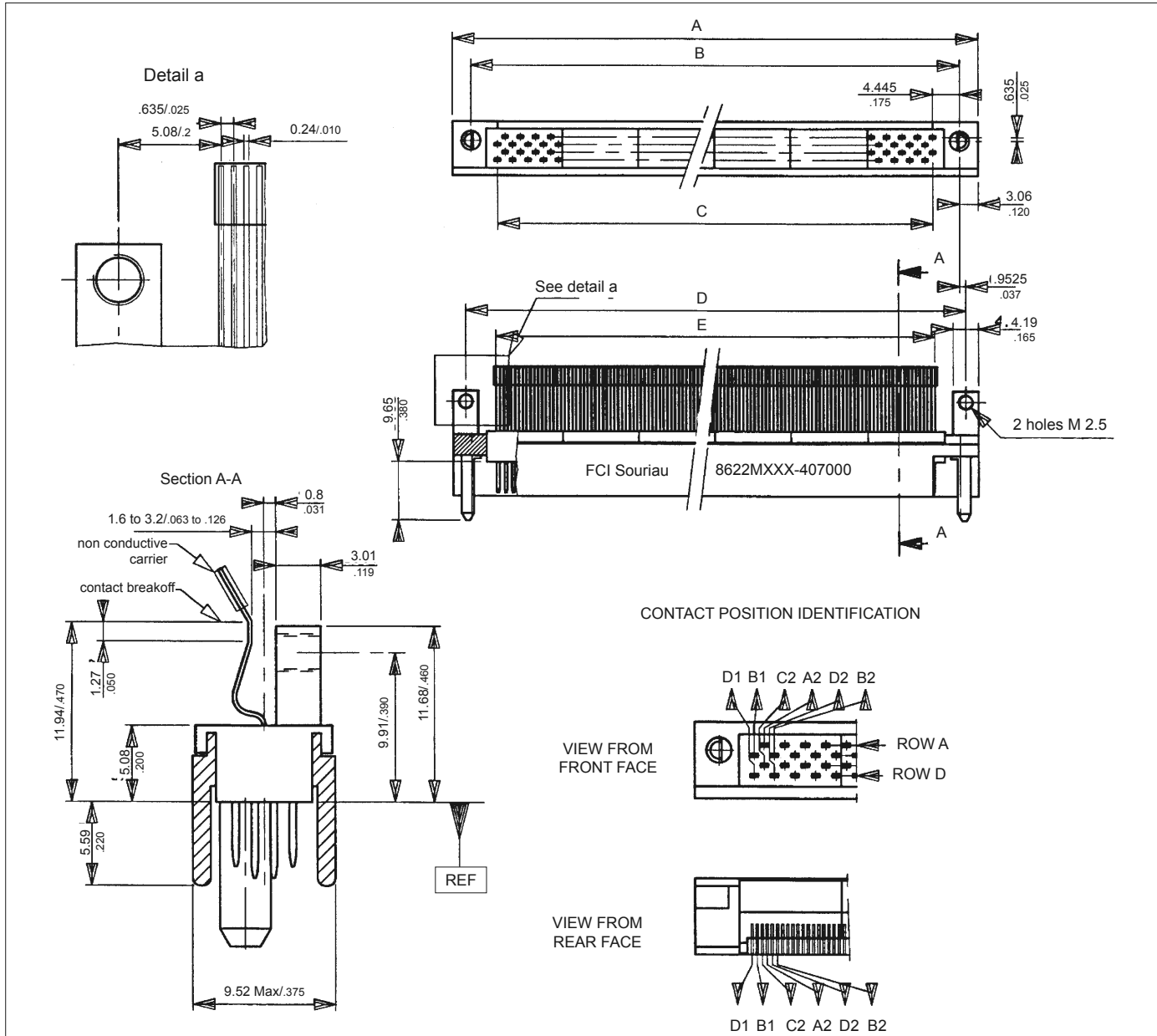

For typical Pwb foot-print, page 515 - Dimension 11.94 (.42) depends on Pwb thickness (please, consult us)

dimension formula		
	example : 196 ways N = 10 modules	dimensions
<b>C</b>	$21.59 + 12.7 \times (N - 2)$ .850 .500	123.19 4.850
<b>A</b>	C + 15.01 .591	138.20 5.441
<b>B</b>	C + 8.89 .350	132.08 5.200
<b>D</b>	C + 10.79 .429	133.98 5.275
<b>E</b>	C + 0.63 .025	123.82 4.875

**typical 196 ways part number**  
**8622 M 196-407000**

**Number of fixings :**  
Over 10 modules, a third fixing is necessary.  
C dimension is then increased of 8.89 mm (.350).  
As an example, a 216 way connector, composed of 11 modules, has a length :  
 $C = 30.48 + 12.7 \times 9 = 144.78 \text{ mm}$   
 $1.200 + 0.500 \times 9 = 5.700 \text{ inch}$



# 8622 NAFI 2

## Male header dimensions

### 8 row connector with SMT terminations

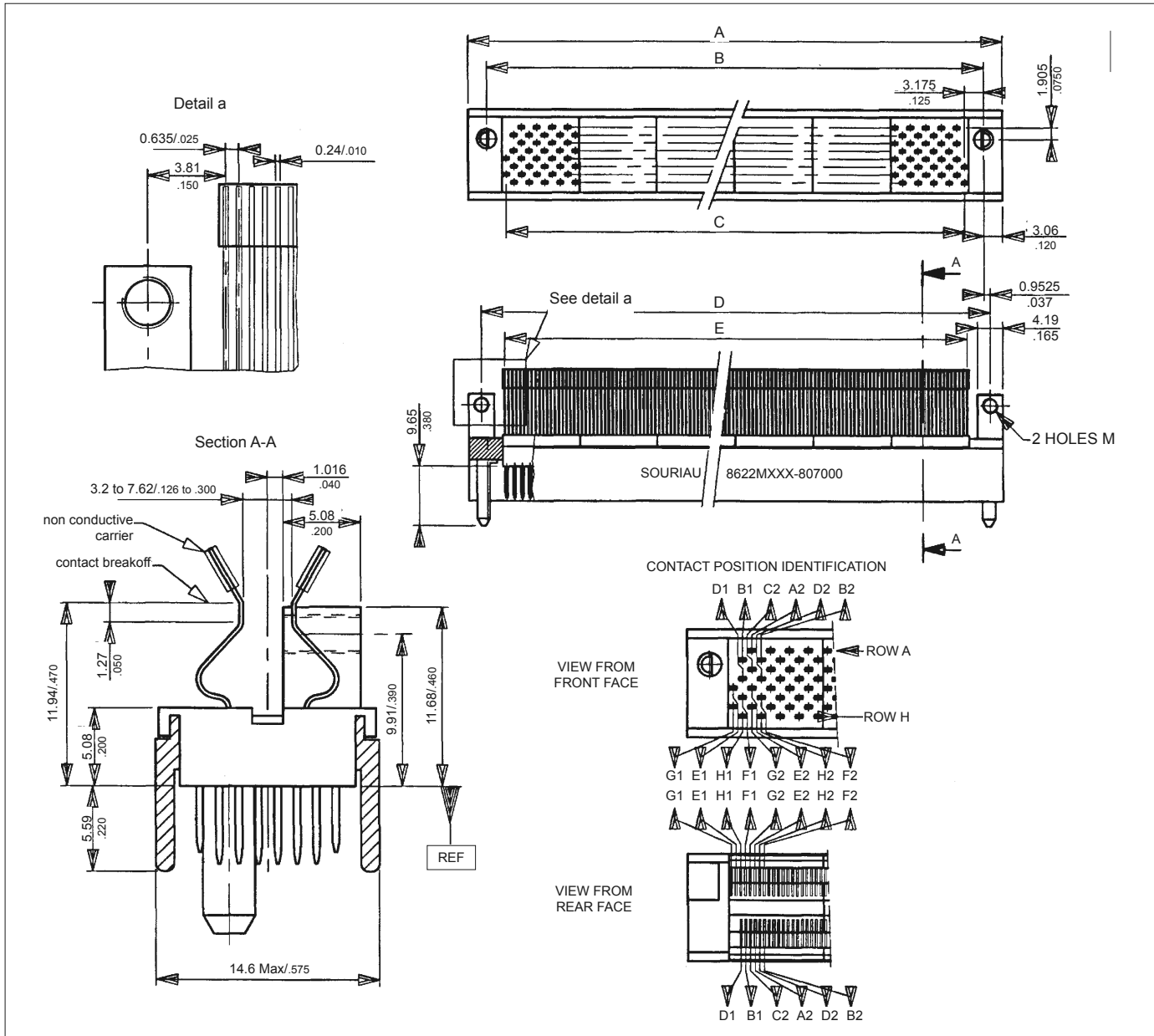

For typical Pwb foot-print, page 515 - Dimension 11.94 (.470) depends on Pwb thickness (please, consult us)

dimension formula		
	example : 396 ways N = 10 modules	dimensions
C	$24.13 + 12.7 \times (N - 2)$ .950 .500	125.73 4.950
A	C + 12.47 .491	138.20 5.441
B	C + 6.35 .250	132.08 5.200
D	C + 8.25 .325	133.98 5.275
E	C + 0.63 .025	126.36 4.975

**typical 396 ways part number  
8622 M 396-807000**

**Number of fixings :**

Over 10 modules, a third fixing is necessary.  
C dimension is then increased of 8.89 mm (.350).  
As an example, a 436 way connector, composed of 11 modules, has a length :

$C = 24.13 + 8.89 + 12.7 \times 9 = 147.32 \text{ mm}$   
 $C = .950 + .350 + .500 \times 9 = 5.800$



# 8622 NAFI 2

## Male header dimensions

8 row connector with flex cable termination (available for 396 ways connector only)

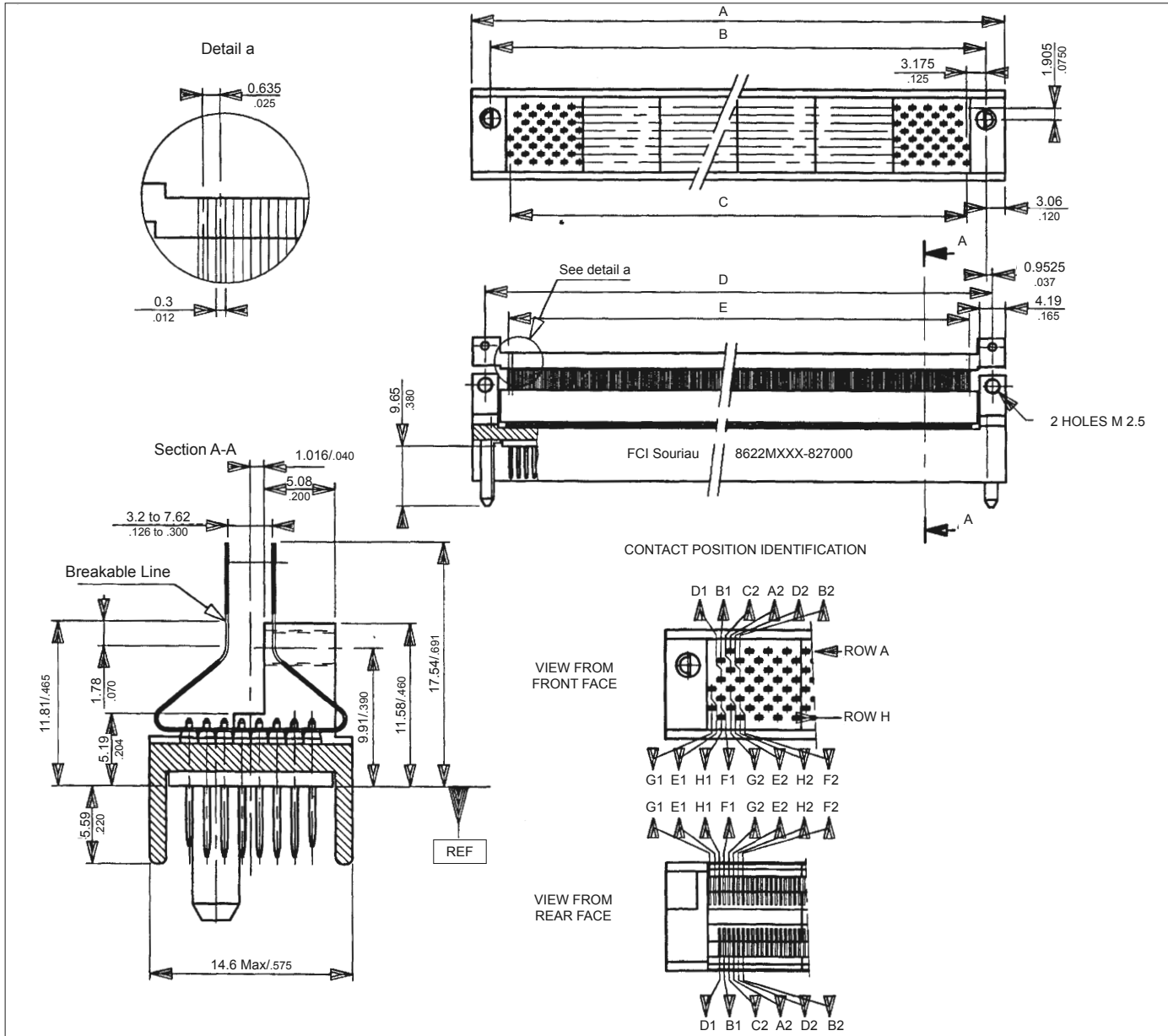

Above drawing is available for a 396 way connector. For any other arrangement, please consult us.  
Dimension 11.81/1.465 depends on Pwb thickness.

dimension formula		
	example : 396 ways N = 10 modules	dimensions
<b>C</b>	$24.13 + 12.7 \times (N - 2)$	125.73
<b>A</b>	$\begin{matrix} .950 & .500 \\ C + 12.47 & \\ & .491 \end{matrix}$	$\begin{matrix} 4.950 \\ 138.20 \\ 5.441 \end{matrix}$
<b>B</b>	$\begin{matrix} C + 6.35 \\ & .250 \end{matrix}$	$\begin{matrix} 132.08 \\ 5.200 \end{matrix}$
<b>D</b>	$\begin{matrix} C + 8.25 \\ & .325 \end{matrix}$	$\begin{matrix} 133.98 \\ 5.275 \end{matrix}$
<b>E</b>	$\begin{matrix} C + 0.63 \\ & .025 \end{matrix}$	$\begin{matrix} 126.36 \\ 4.975 \end{matrix}$

**typical 396 ways part number**  
**8622 M 396-827000**

**Number of fixings :**  
Over 10 modules, a third fixing is necessary.  
C dimension is then increased of 8.89 mm (.350).  
As an example, a 436 way connector, composed of 11 modules, has a length :  
 $C = 24.13 + 8.89 + 12.7 \times 9 = 147.32 \text{ mm}$   
 $C = .950 + .350 + .500 \times 9 = 5.800 \text{ inch}$



# 8622 NAFI 2

## Male header dimensions

4 and 8 row connector, solder PC Tails or press-fit and WW terminations

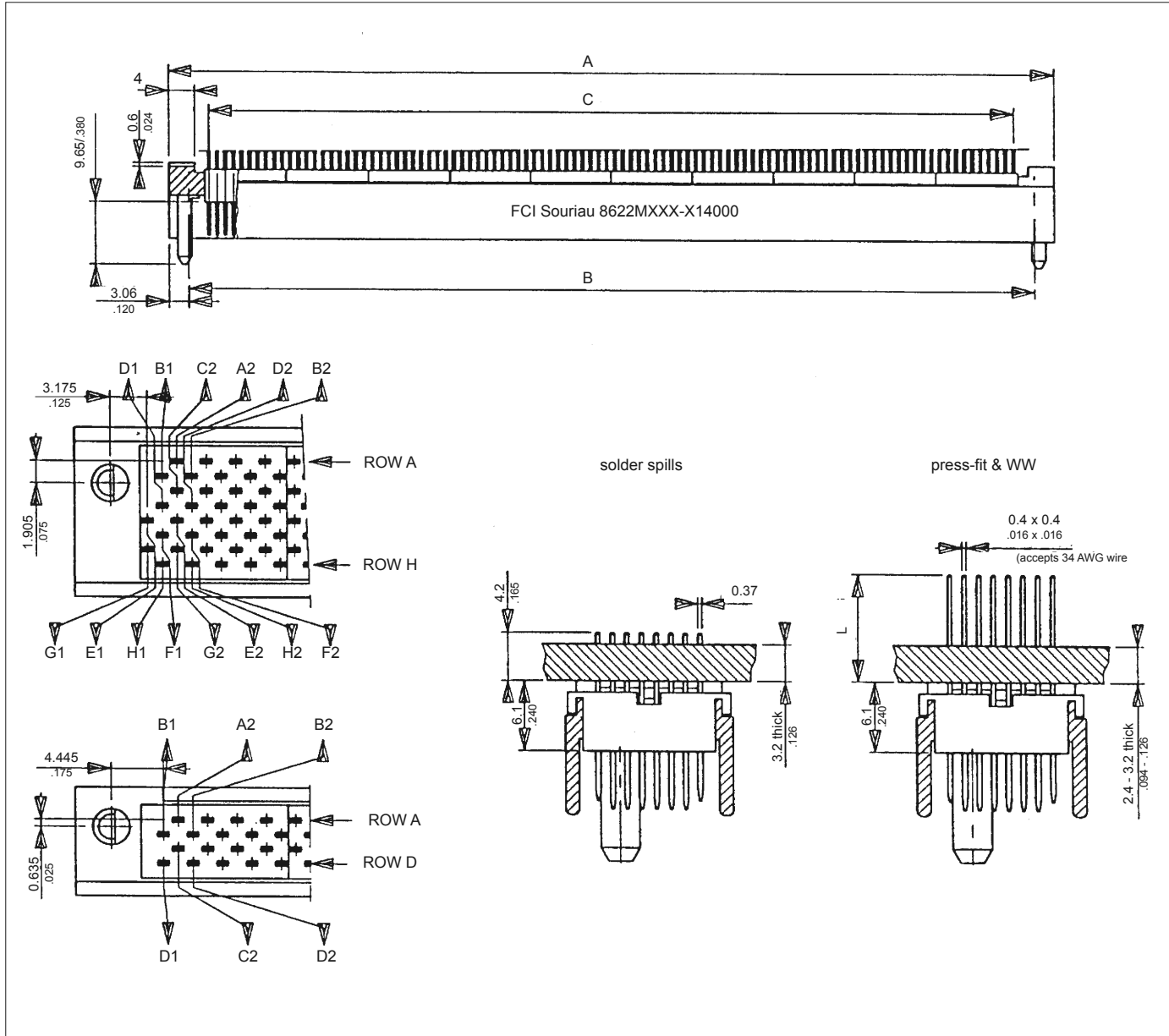

For typical Pwb foot print, see next page. Consult us for all orders.

dimension formula (N = 10 modules)				
	8 rows		4 rows	
	formula	example 396	formula	example 196
<b>C</b>	$24.13 + 12.7 \times (N - 2)$	125.73	$21.59 + 12.7 \times (N - 2)$	123.19
	.950 .500	4.950	.850 .500	4.850
<b>A</b>	$C + 12.47$	138.20	$C + 15.01$	138.20
	.491	5.441	.591	5.441
<b>B</b>	$C + 6.35$	132.08	$C + 8.89$	132.08
	.250	5.200	.350	5.200

extensions length (L)	
nbr of wraps	L
3	10.16
	.400
2	7.34
	.289
1	5.59
	.220
0	4.05
	.159

Above table, is given for 10 modules, add 8.89 mm/.350 to C dimension.



# 8622 NAFI 2

## Male header dimensions 4 and 8 row connectors typical Pwb foot-print

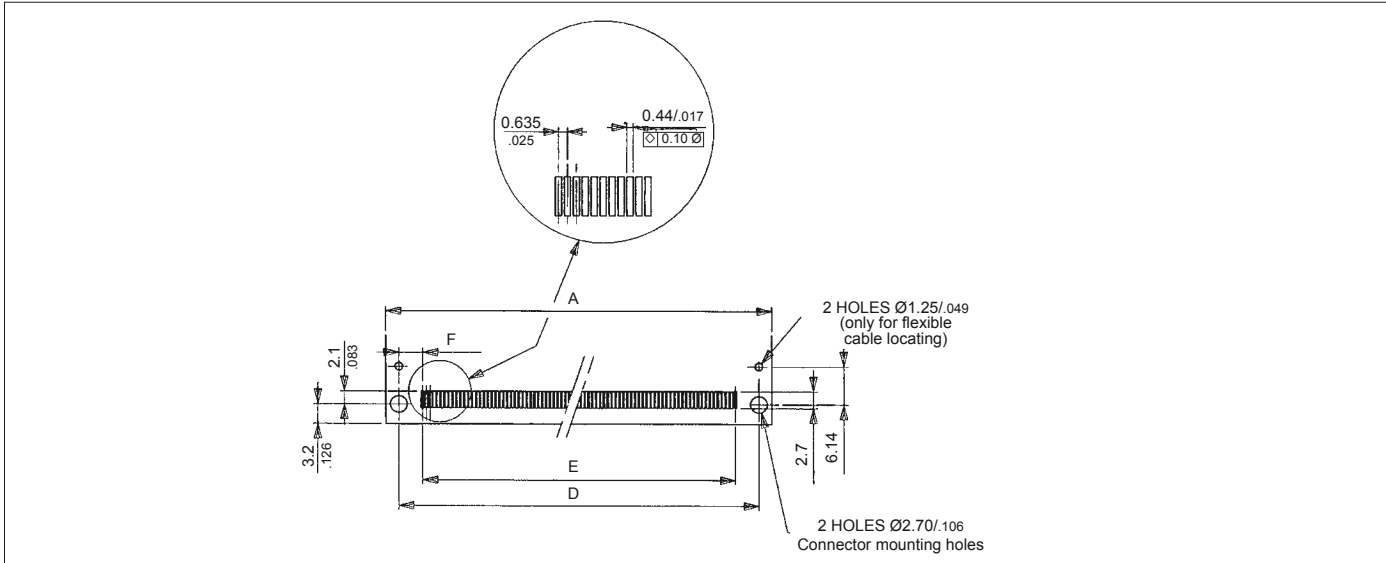

dimension formula (N = 10 modules)				
	8 rows		4 rows	
	formula	example 396	formula	example 196
<b>C</b>	$24.13 + 12.7 \times (N - 2)$ .950 .500	125.73/4.950	$21.59 + 12.7 \times (N - 2)$ .850 .500	123.19/4.850
<b>A</b>	C + 12.47/.461	138.20/5.441	C + 15.01/.591	138.20/5.441
<b>D</b>	C + 8.25/.325	133.98/5.275	C + 10.79/.429	133.98/5.275
<b>E</b>	C + 0.63/.025	126.36/4.975	C + 0.63/.025	123.82/4.875
<b>F</b>	3.81/.150	3.81/.150	5.08/.200	5.08/.200

Above table, is given for 10 modules or less, over 10 modules, add 8.89 mm/.350 to C dimension.

## 4 and 8 row, straight solder PC tail or press-fit and WW PCB foot-print

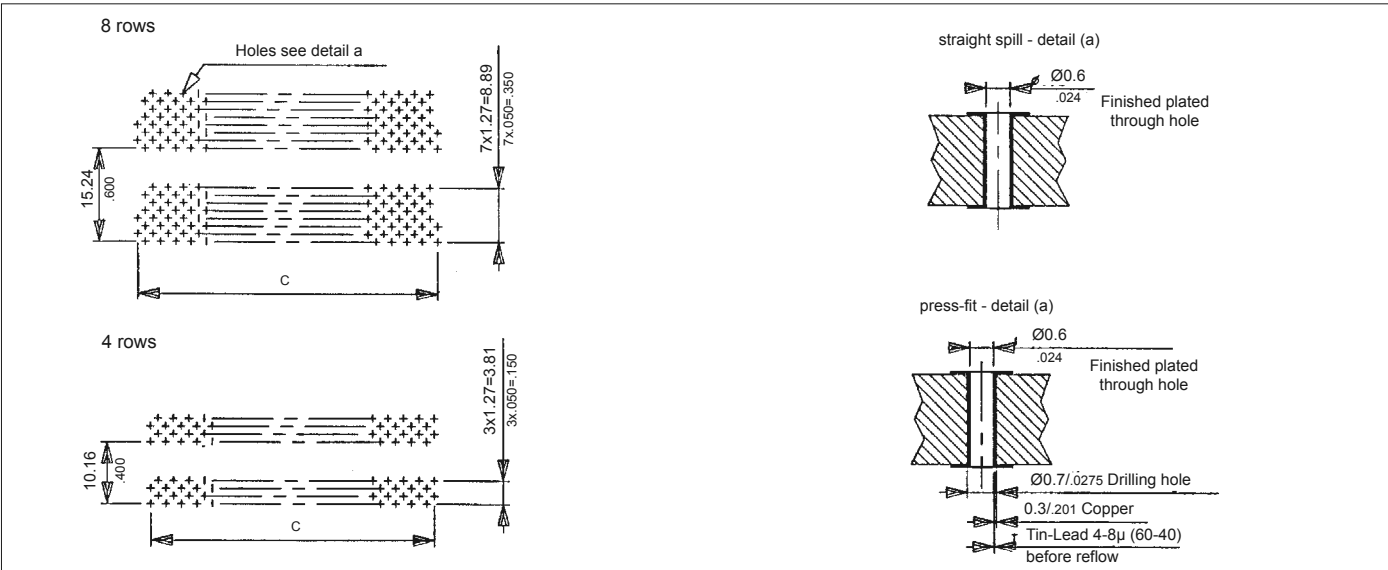

dimension formula (N = 10 modules)				
	8 rows		4 rows	
	formula	example 396	formula	example 196
<b>C</b>	$24.13 + 12.7 \times (N - 2)$ .950 + .500 X (N - 2)	125.73 4.953	$21.59 + 12.7 \times (N - 2)$ .850 + .500 X (N - 2)	123.19 4.850

Above table, is given for 10 modules or less, over 10 modules, add 8.89 mm/.350 to C dimension.



# 8622 NAFI 2

## Male header dimensions Mixed signal and size-16 contacts

The 8 row end insulator modules are available either with 40 signal or 4 size 16 cavities for power, coaxial or fiber optic contacts. The AWG 16 contacts are ordered and delivered separately. The following example shows a 8 row, 320 signal and 8 power contacts. Please, consult us for any other configuration.

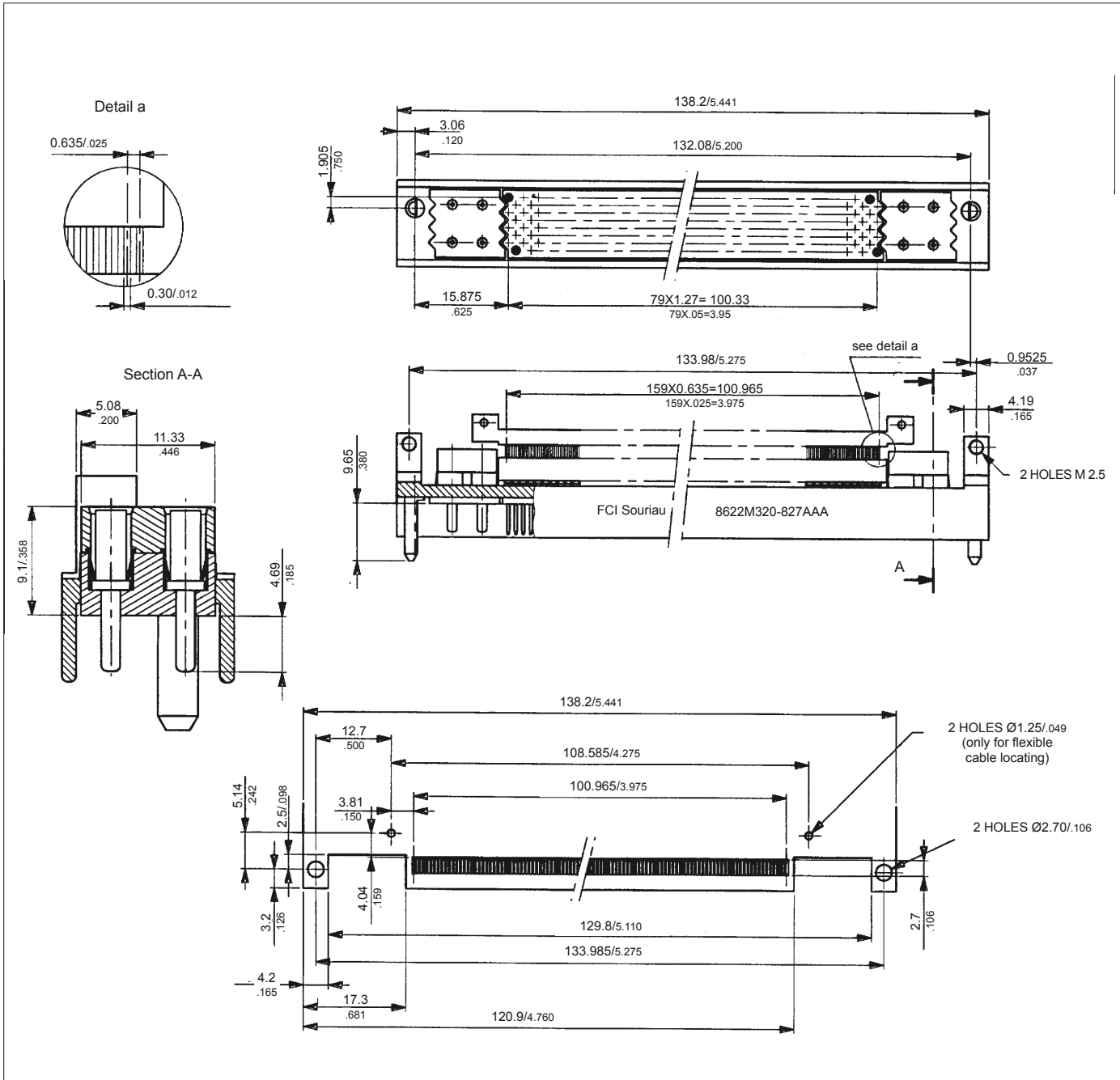

AWG 16 contact part number		
sex of contact	power contacts	coaxial contact
pin	M39029/58-364	M39029/76-A

320 + 8 connector part number
8622 M320-827xxx*
*TBD



# 8622 NAFI 2

## Female receptacle dimensions 4 and 8 row, solder PS Tails or press-fit and wire-wrap terminations

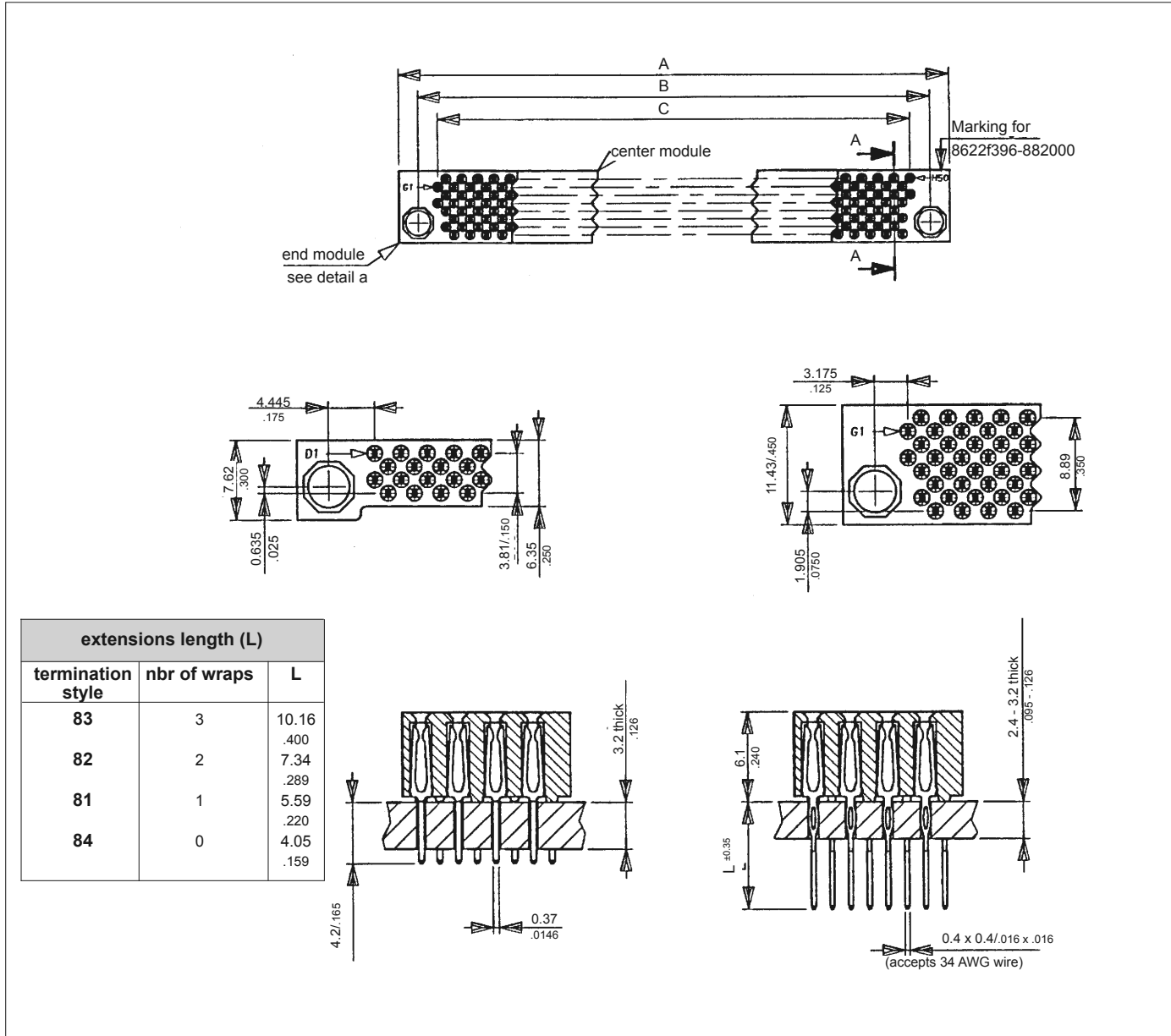

For typical Pwb foot print, see next page.

dimension formula (N = 10 modules)					part numbers	
	8 rows		4 rows		396 way press fit	8622F396-882000
	formula	example 396	formula	example 196	396 way solder spills	8622F396-814000
<b>C</b>	$24.13 + 12.7 \times (N - 2)$ .950 .500	125.73 4.950	$21.59 + 12.7 \times (N - 2)$ .850 .500	123.19 4.850	<b>196 way press fit</b>	8622F196-482000
<b>A</b>	$C + 12.47$ .491	138.20 5.441	$C + 15.01$ 1 .591	38.20 5.441		
<b>B</b>	$C + 6.35$ .250	132.08 5.200	$C + 8.89$ .350	132.08 5.200		

Above table, is given for 10 modules or less. Over 10 modules, add 8.89 mm/.350 to C dimension.



# 8622 NAFI 2

## Female receptacle dimensions

### 4 and 8 row connector with solder PC Tails or press-fit PCB foot-print

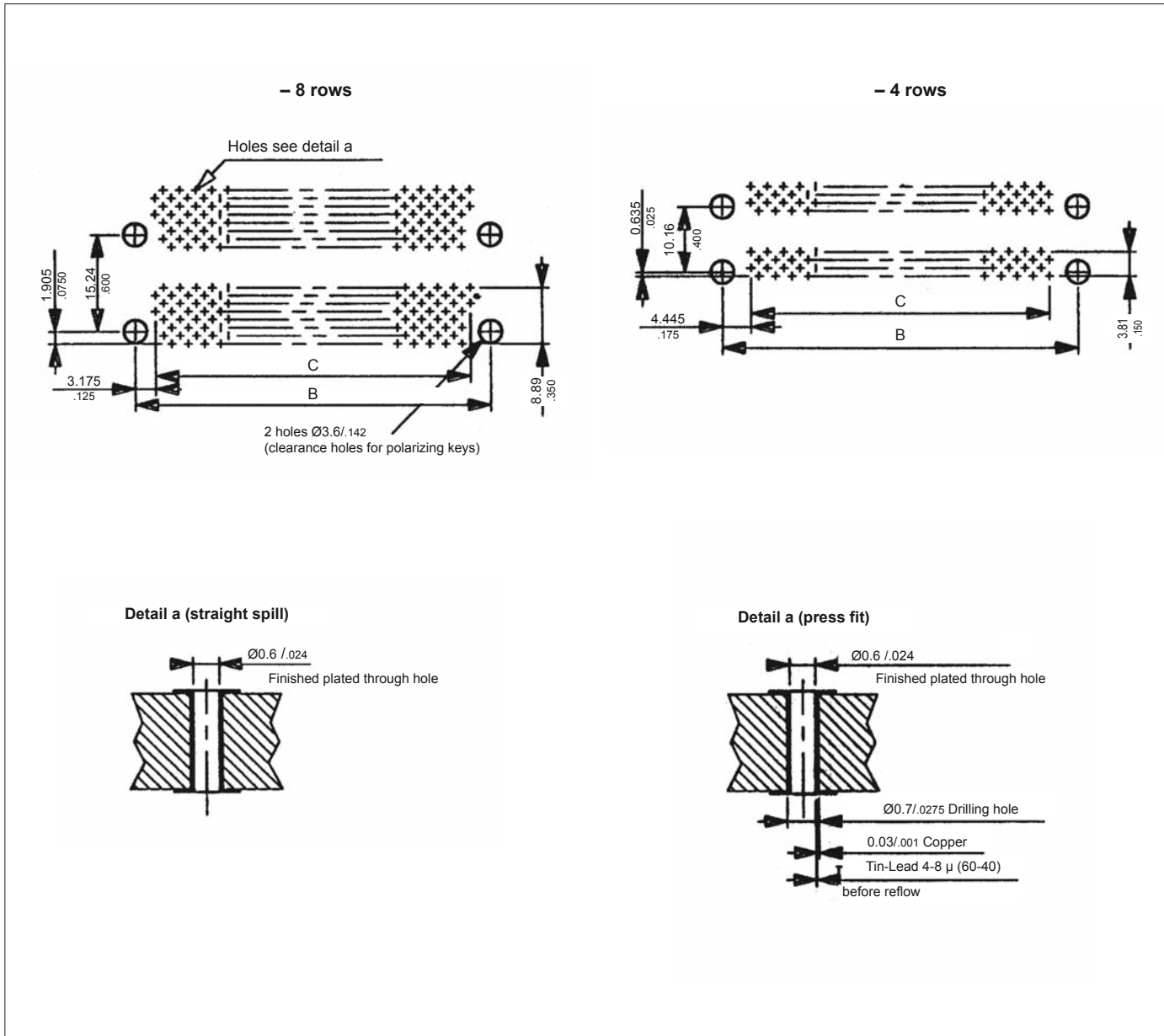

dimension formula (N = 10 modules)				
	8 rows		4 rows	
	formula	example 396	formula	example 196
<b>C</b>	$24.13 + 12.7 \times (N - 2)$ .950 .500	125.73 4.950	$21.59 + 12.7 \times (N - 2)$ .850 .500	123.19 4.850
<b>B</b>	$C + 6.35$ .250	132.08 5.200	$C + 8.89$ .3505	132.08 .200

Above table is given for 10 modules or less. Over 10 modules, add 8.89 mm/.350 to C dimension.



# 8622 NAFI 2

## Female receptacle dimensions Mixed signal and size 16 contacts

The 8 row end insulator modules are available either with 40 signal or 4 size 16 cavities for power, coaxial or fiber optic contacts. The AWG 16 contacts are ordered and delivered separately. The following example shows a 8 row, 320 signal and 8 power contacts. Please, consult us for any other configuration.

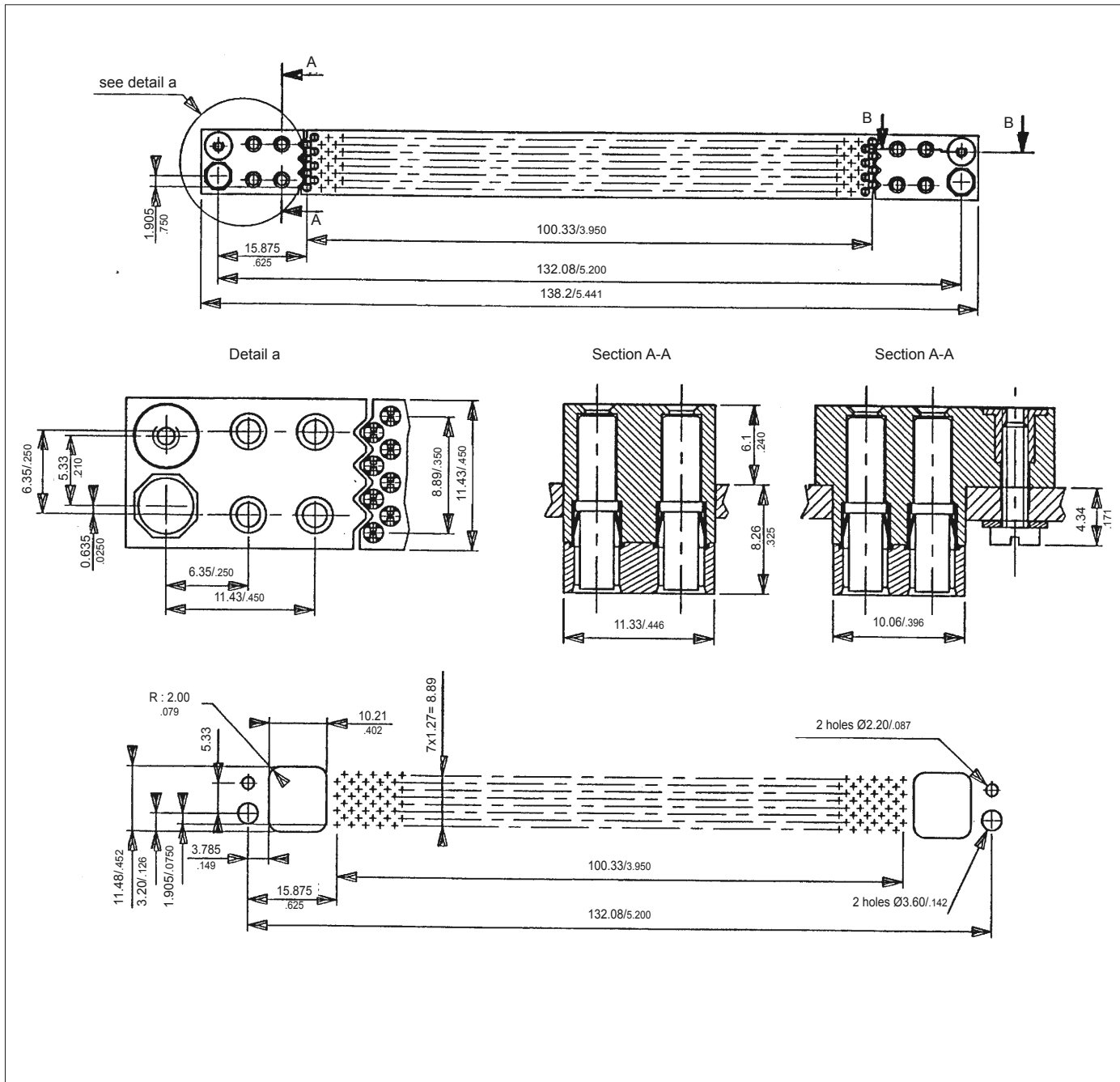

AWG 16 contact part number		
sex of contacts	power contacts	coaxial contacts
socket	M39029/57-358	M39029/78-B

(320 + 8) connector part number
8622 F320-882xxx**
**TBD



# 8622 NAFI 2

## Polarizing and coding devices

Male and female connectors are equipped with D shaped polarizing devices of the standard NAFI connectors. Coding key and pin, in any cases, are delivered loose, in bags of 10 units. The female receptacle is fitted with octagonal keys cavities built in both end modules. The male header is always fitted with coding pins holes.

**Coding key**  
 The key meet the MIL 28754/39B specification. It is hand positionned and jammed with an hand tool (see page 21)

**Part number : 8602-9303A SP10**

**Coding pin**  
 The pin are installed by customer in their selected angular orientation with an hand tool (see page 21)

**Part number : 8622-9007SP10**

**Polarization**  
 Besides example is shown in position C.

## Tooling

### Female press-fit receptacle

The mother board is generally supplied completely assembled and tested by Souriau under customer specifications. In some particular applications, the customer is able to assemble himself the press-fit receptacles on its own backplane.

In any cases, please, contact us for any information.

### Coding devices settlement

Coding pins settlement demands recommended special hand tools :

part number	
Male pin	8622-1000
Female key	8622-1001
Hand press and rest	8622-1002

### Female contact repair kit

The press-fit contacts into the board may be removed 3 times from the card (for repair purposes for example) this operation is handled with the following hand tool :

part number
8622-1003

### Female contact press-fitting hand-tool

This tool is composed of a X-Y indexed table bench and insertion head as well.

part number
8622-1004

### Male header soldering on the daughter board

Depending on the required termination style (Flex-cable or one-piece SMT contacts). On request, a special soldering recommendation sheet is available. Please, consult us.

