



8 BUS Series

Applications

Bifilar BUS lines for multiplex transmission

Standards

derivated from
MIL-C 26482 Series II
NFC 93422 HE 312
83723 Serie I



Description

- High level RFI / EMI
- Rear removable contacts
- Two contact layouts
 - shell 22 : 9 standard contacts + 4 BUS
 - shell 24 : 41 standard contacts + 2 BUS

Characteristics

Mechanical

- Shell : aluminum alloy
- Insulator : thermoset
- Contacts : copper alloy
- Vibrations : 10 to 20 000 Hz, acceleration 20g
- Shock : 100g, 6ms

Electrical

- Withstanding voltage : 1500 Vrms Max
- Current rating : 7,5 A
- Insulation resistance : $\geq 5000 \text{ M}\Omega$
- Contact resistance : # 20 contact : $\leq 4 \text{ m}\Omega$
bifilar inner contact : $\leq 4 \text{ m}\Omega$
- Contact bifilar impedance at 3 GHz
 - between central contacts : 68 Ω
 - between central contacts and shielding of the bifilar contact : 42 Ω

Climatic

- Temperature range : - 55°C to +125°C
- Endurance : 500 operations
- Sealing : immersion at low pressure : 33 mbar
- Resistance to salt spray : 48 hours
- Damp heat : 21 days or 10 cycles according to MIL-STD 202 method 106

Ordering information

basic series	8 BUS 0 R 22 - 09 4 S N ...
Shell type	0 - square flange receptacle (backnut or straight backshell) 6 - plug with backnut or straight backshell 8 - plug with elbow backshell 7 - jam nut receptacle (backnut or straight backshell) 9 - flange mounted plug with «Twist pull» backshell
Type	R - backnut C - cable clamp O - supplied without backshell
shell size	22 or 24 - (plug 9 C : shell 22 only)
contacts # 20	09 - shell 22 41 - shell 24
bifilar shielded contacts	4 - shell 22 2 - shell 24
	P - male contact S - female contact
polarization	N - normal, W and X (see table next page)
specifications	see table next page



8 BUS Series

Specifications

	plating		
	olive green cadmium	black anodized	yellow cadmium
bus contact for FILECA cable 2709/12	without spec.	031	032
shell 22 supplied with 2 BUS contacts for FILECA wire 2709/12 and 2 dummy contacts	001	041	042
large barrel size 20 contacts and BUS contacts for FILECA 2709/12 cable	008	039	040
shell 22 supplied with 2 BUS contacts for FILECA wire 2709/12 and 2 dummy contacts + # 20 large barrel contacts	009	050	051
bus contact for FILECA 2709/3 cable	200	231	232
shell 22 supplied with 2 BUS contacts for FILECA 2709/3 cable and 2 dummy contacts	201	241	242
bus contact for FILECA 2709/3 cable + # 20 large barrel contacts	208	239	240
shell 22 supplied with 2 BUS contacts for FILECA 2709/3 cable and 2 dummy contacts + # 20 large barrel contacts	209	250	251
bus contact for FILECA 2709/9 cable	300	331	332
shell 22 supplied with 2 BUS contacts for FILECA 2709/9 cable and 2 dummy contacts	301	341	342
bus contact for FILECA 2709/9 cable + # 20 large barrel contacts	308	339	340
shell 22 supplied with 2 BUS contacts for FILECA 2709/9 cable and 2 dummy contacts + # 20 large barrel contacts	309	350	351
delivery without contact	L	031 L	032 L

Contact layouts

viewed from front face of male insulator

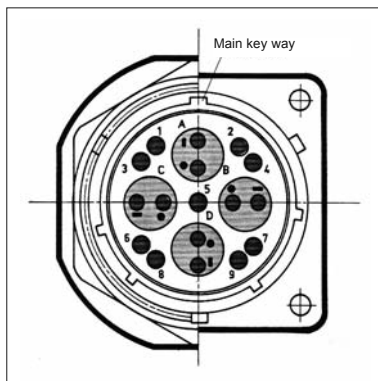

shell 22
9 contacts # 20
4 shielded bifilar contacts

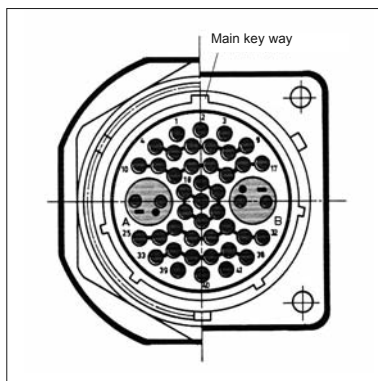

shell 24
41 contacts # 20
2 shielded bifilar contacts

Polarization

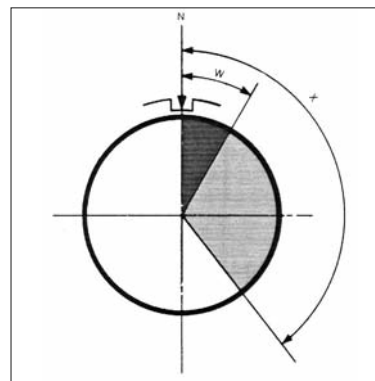

	W	X
shell 22	30°	142°
shell 24	90°	225°

Part numbers

cable type	BUS contacts			# 20 contacts		
	FILECA 2709/12	FILECA 2709/3	FILECA 2709/9	standard small barrel	specific large barrel	
male contact	set	8532- 10	8532- 06	8532- 16	8526-1348	8522-2349 A
	central	8630-162	8630-162	8630-162		
female contact	set	8532- 11	8532- 07	8532- 17	8526-1344	8520-292
	central	8630-629	8630-629	8630-629		
cable acceptance				0,21 to 0,60 mm ²	0,38 to 0,93 mm ²	
reducing sleeve				8522-2142		
cable acceptance with reducing sleeve				0,09 to 0,21 mm ²		
∅ over insulation (Max)	5,2 mm	3,8 mm	4,6 mm	0,98 to 2,11 mm		
dummy contact	8532-148		8532-148			
filler plug				8522-389A		



8 BUS Series

Dimensions

Square flange receptacle 0 type

square flange receptacle with backnut

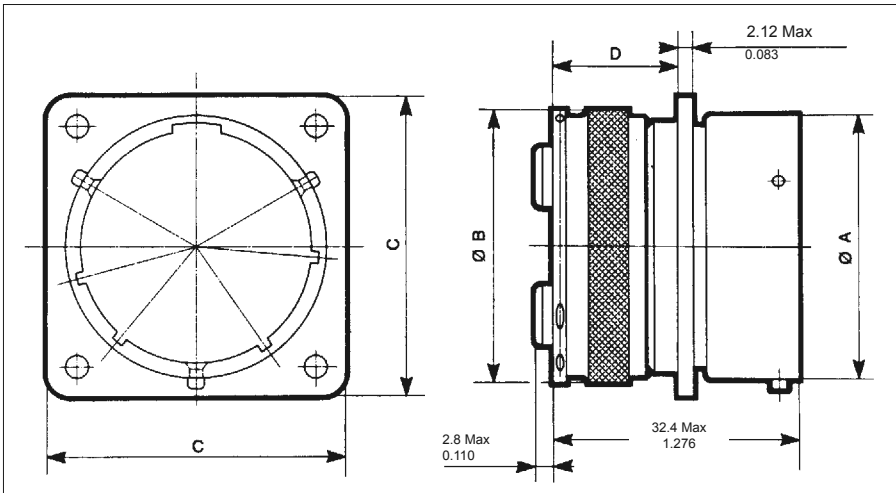

shell	A Max	B Max	C Max	D Max
22	35 1.378	36.2 1.425	40 1.575	16.5 .650
24	38.2 1.504	39.4 1.551	43.2 1.701	16.5 .650

square flange receptacle with straight cable clamp

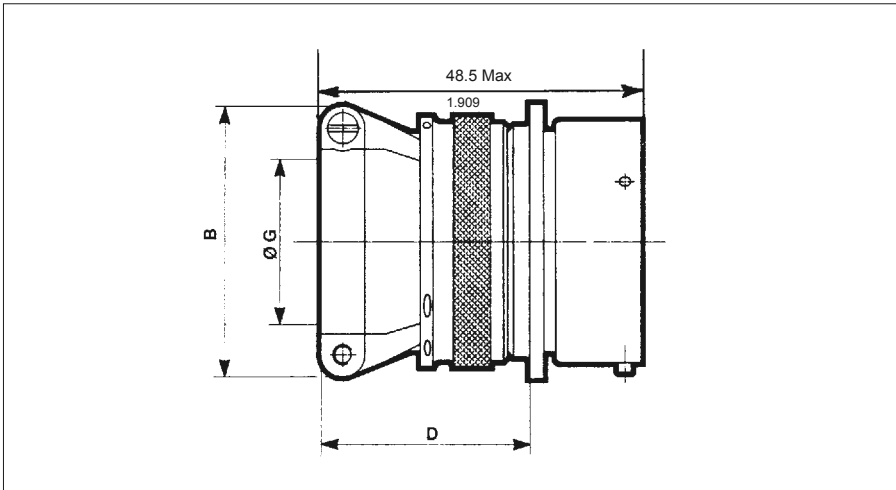

shell	B Max	D Max	G Max
22	39 1.535	31.3 1.232	23.9 .941
24	42.7 1.681	31.3 1.232	27 1.063

Panel cut-out

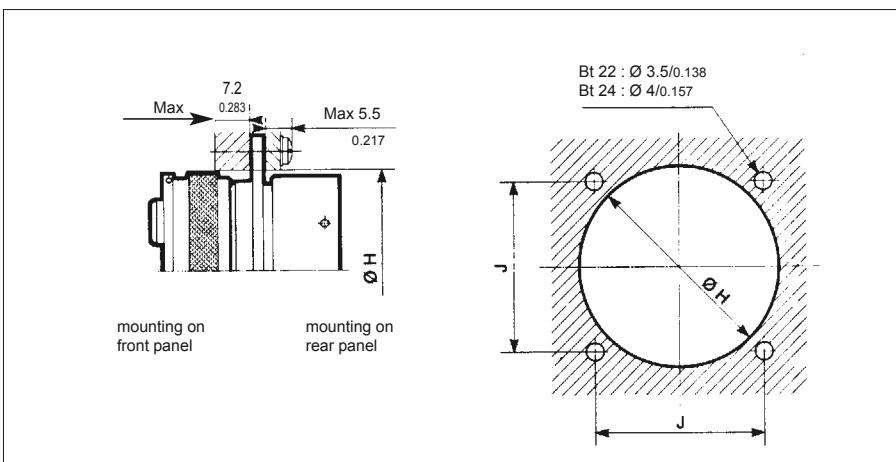

shell	H	J
22	37.7 1.484	31.75 1.250
24	41 1.614	34.92 1.375



8 BUS Series

Jam nut receptacle 7 type receptacle with backnut

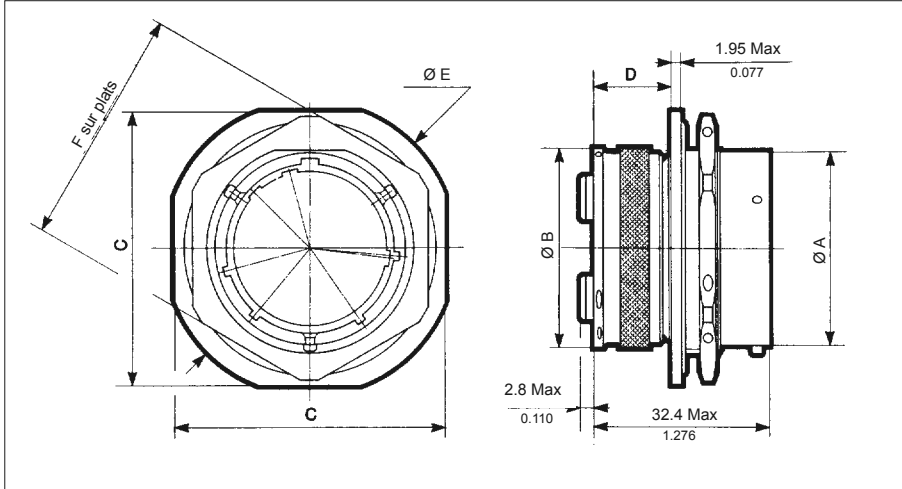

shell	A Max	B Max	C Max	D Max	E	F
22	34.95 1.376	36.33 1.430	49.43 1.946	14.5 .571	52.6 2.071	42.9 1.689
24	38.12 1.501	39.48 1.554	52.6 2.071	14.5 .571	55.75 2.195	46.2 1.819

Square flange receptacle with straight cable clamp

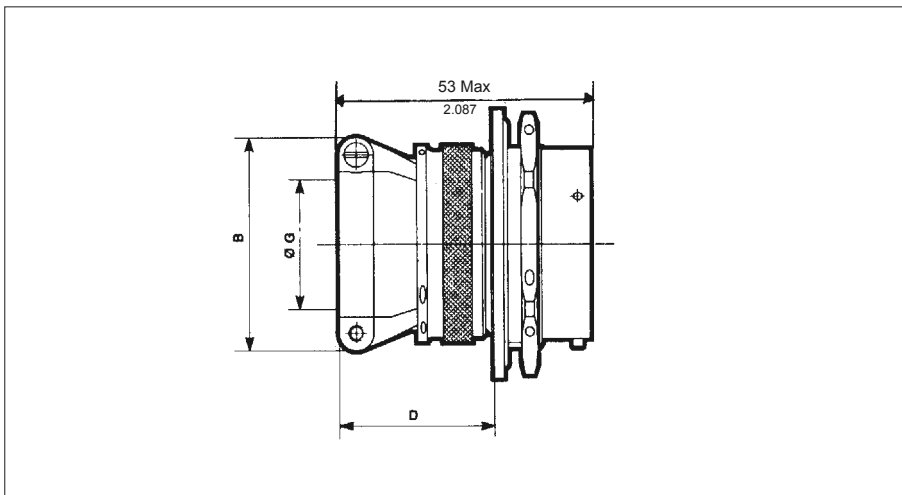

shell	B Max	D Max	G Max
22	39 1.535	29.3 1.154	23.9 .941
24	42.7 1.681	29.3 1.154	27 1.063

Panel cut-out

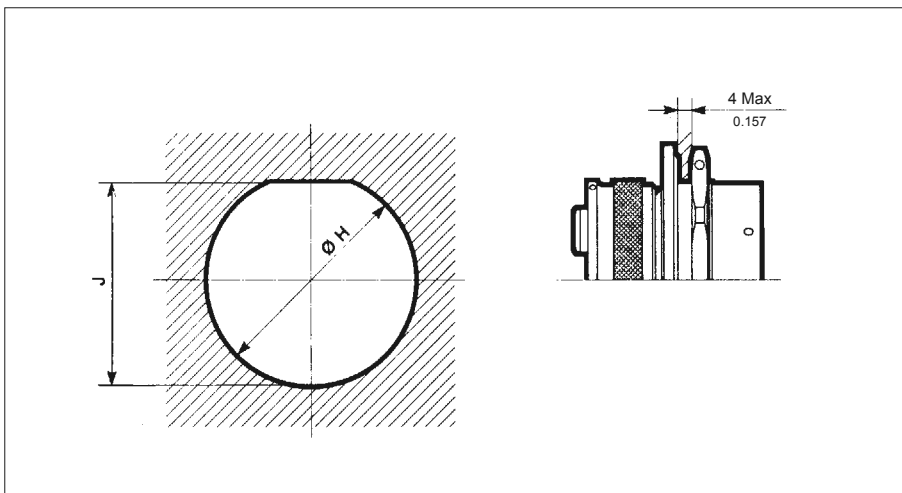

shell	H	J
22	38.4 1.512	36.8 1.449
24	41.5 1.634	39.9 1.571



8 BUS Series

Plug 6 type plug with backnut

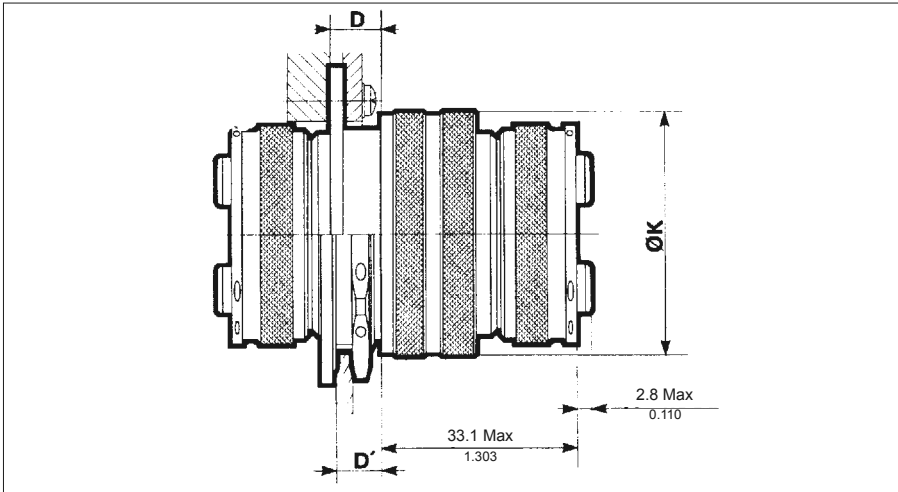

shell	K Max	L Max	D Max	D' Max	G Max
22	41.8 1.646	39 1.535	5 .197	7 .276	23.9 .941
24	45.1 1.776	42.7 1.681	5 .197	7 .276	27 1.063

plug with straight cable clamp

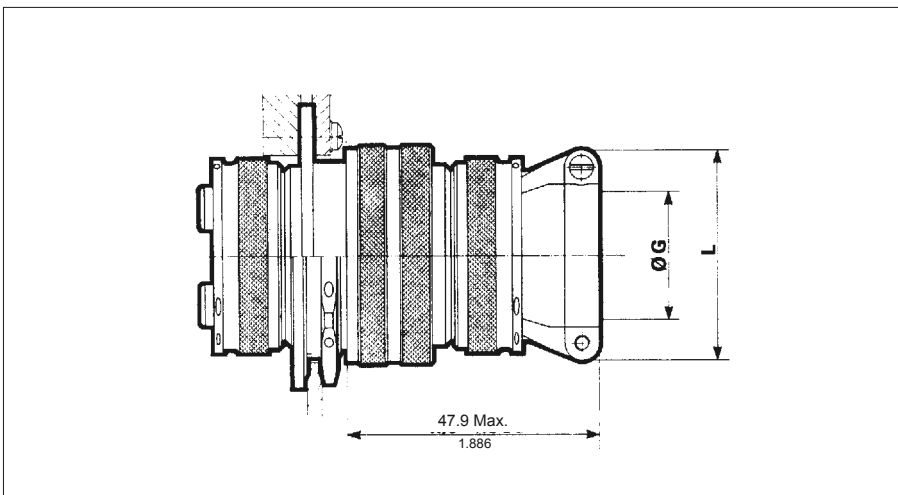

Plug 8 type (only with elbow cable clamp backshell)

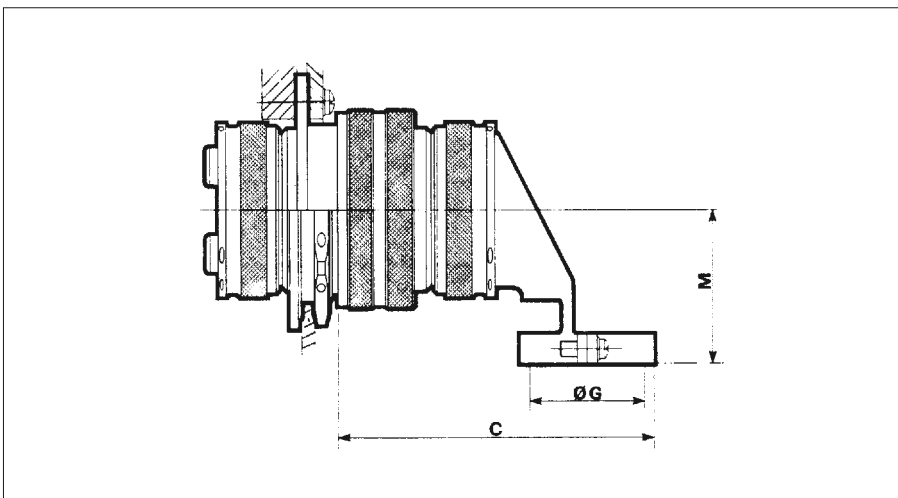

shell	C Max	M Max	G Max
22	65.6 2.583	31.9 1.256	23.9 .941
24	68.6 2.701	33.4 1.315	27 1.063