



8818 Series

Applications

Submarine and subsea defense equipment

Standards



Descriptions

Custom design waterproof series
 Stainless steel shell material
 Glass fused and teflon insulator design
 3 layouts available from 5 to 10 contacts
 30 bar working pressure

Characteristics

| Part number range | Layout | Contact section | Maximum wire section | Working voltage (Volt) | Maxi. current rating per contact (A) | Maxi. bundle current capacity per contact (A) | Subsea enviro. class (Max. working pressure (bar)) |
|---------------------------------|--------|--------------------------|----------------------|------------------------|--------------------------------------|---|--|
| 8818 (09 and 22) | 5 cts | 3 cts # 16 (Ø 1,57) .062 | 1.93 | 40 | 13 | 1 | 30 bar |
| | | 2 cts # 12 (Ø 2,38) .094 | 4.5 | | | | |
| 8818 (11,12,13,15 16,18 and 19) | 7 cts | 5 cts # 16 (Ø 1,57) .062 | 1.93 | 40 | 13 | 1 | 30 bar |
| | | 2 cts # 12 (Ø 2,38) .094 | 4.5 | | | | |
| 8818 (24A, 25A and 26 A) | 10 cts | 8 cts # 16 (Ø 1,57) .062 | 1.93 | 600 | 13 | 5 | 35 bar |
| | | 2 cts # 10 (Ø 3,09) .122 | 7.9 | | | | |

Example of cable equipment

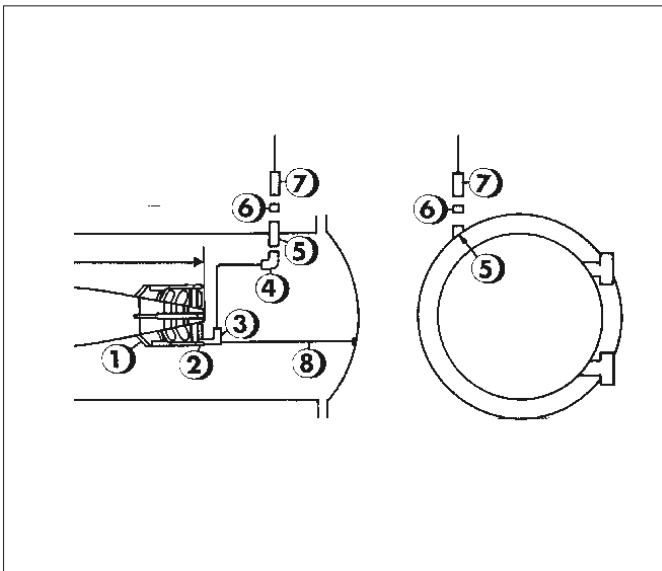
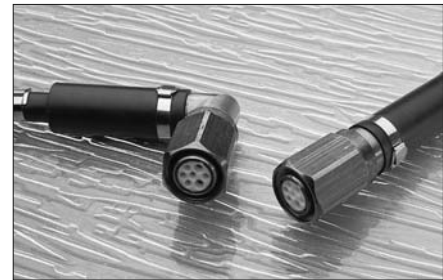

| 8818 Connectors Series | | |
|------------------------|---|--|
| Item | Designation | Part number |
| | Penetrator | 8864-1750 |
| | Precabled | - |
| | Torpedo internal harness | 8818-09 EL |
| | Quick release plug (wired x 1 m) | 8818-22 |
| | Right underwater SURA plug | - |
| | Internal torpedo tube harness | 8818-11 (L = 0,70 m) 8818-12 (L = 15 m) |
| | Glass fused thrubulkhead receptacle for torpedo tube door | 8818-13 |
| | Sealing cap for | 8818-14 |
| | Straight SUEP plug | 8818-15 (L = 10 m) 8818-16 (L = 5 m) |
| | Steel wire loop | - |



8828 Series

Applications

Electrical connector for new light weight torpedo generation

Description

- Connector with quick release locking
- Electrical connector with pump contacts on the plug
- Fitting between cable and plug is made by a gland system



Characteristics

Mechanical

- Total strain to start the pressure at the 14 contacts together : 4 to 7 daN
- Max strength to connect the plug : 45 daN
- Max strength to release the plug : 23 daN
- Working pressure on the receptacle front face : 70 bars (115 bars during 15 mn)
- Test pressure on the receptacle rear face : 15 bars during 10 mn

Electrical

- Layout : 14 contacts
- Contact size : gauge 16
- Contact termination : soldering
- Current rating : 3A (8A during 30s)
- Working voltage : 220 V

Material

- Receptacle shell : aluminum alloy with cadmium plating
- Receptacle insulator : thermoplastic
- Plug shell : brass with cadmium plating
- Plug insulator : molded Epoxy
- Locking claw : steel with cadmium plating

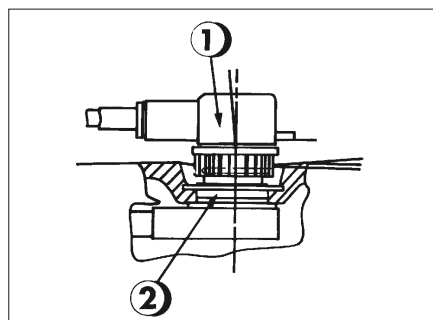

Part numbers

| 8828 Connector Series | | |
|-----------------------|----------------------------------|-------------|
| Item | Designation | Part number |
| | Quick release plug | 8828-01A |
| | Umbilical receptacle for torpedo | 8828-02A |



8479 Series

Applications

Submarine and subsea defense equipments



Description

Cable assembly equipment with guillotine system for wire guided torpedoes.

Characteristics

| Part number range | Layout | Contact section (mm ²) | Maximum wire section (mm ²) | Working voltage (Volt) | Maximum current rating per contact (A) | Maximum bundle current capacity per contact (A) | Subsea environment class (Max. working pressure (bar)) |
|-------------------|---|------------------------------------|---|------------------------|--|---|--|
| 8479 | 65 cts # 16 ($\varnothing = 1.57 \text{ mm}$) 0.062 | 1.93 | 1.34 | 250 | 13 | 5 | 50 bar/15' (mated) Open face receptacle = 25 bar |

Ordering information

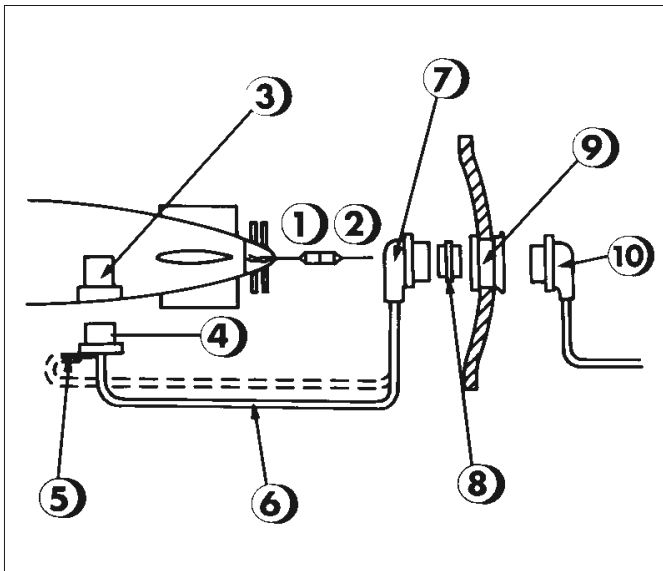

| Item | Designation | Part number |
|------|---|--------------------------------|
| 3 | Hermetic male receptacle for torpedo | 8479-21 (ex 8479-18) |
| 4 | Non hermetic female plug for torpedo | 8479-22 (ex 8479-19) |
| 5 | Wire cutting system (guillotine) | 8479-27 (ex 8479-03) |
| 6 | "A" cable for complete torpedo to torpedo tube door | 8479-28 |
| 7 | Hermetic male plug for internal torpedo tube door (ex 8479-01A) | 8479-24 |
| 8 | Hermetic male test cap connector | 8479-25 |
| 9 | Female/female thrubulkhead connector for torpedo tube door | 8479-30 |
| 10 | Non hermetic male plug for external | 8479-23 (ex 8479-20) |