



8810 Series

Applications

All underwater mateable equipments.

Standards



Description

The 8810 range is designed to be wet or underwater mated and can be used at depths down to 3000 meters. The metal body shells feature rugged, square cut coupling threads to enhance the 8810's suitability for repeated coupling and uncoupling in severe environmental conditions. Connector front faces can withstand either 150 or 300 bars uncoupled wet pressure. Underwater sealing caps are available for use on connectors power on or for long term immersion.

Characteristics

Mechanical

- Pressure resistance : working pressure (Mated or non mated connectors)
 - Shell sizes 1, 2, 3, 4, 7
 - Fitted with cable gland endbell : 300 bar
 - Fitted with longitudinally sealed : 300 bar endbell
 - Shell sizes 5, 6
 - Fitted with all endbell types : 150 bar
- Endurance 500 mating/unmating operations
- Metal shell* : Nickel aluminum bronze
- Insulators : Molded rubber
- Contacts : Gold plated copper alloy
- Band and buckles stainless steel 316L
- Stainless steel 316L, inconel, monel, titanium, aluminum... available on request

Operational

- Working temperature
 - Ambient : -30°C + 70°C
 - Subsea : -3°C + 40°C
- Shocks 75 g - 11 ms (3 axis)
 - Shell size 1, 2, 3, 4, 7
- Vibrations
 - 0.1 Hz to 1 Hz (25 mm amplitude peak to peak 50)
 - 1 Hz to 5 Hz (0.1 g acceleration)
 - 5 Hz to 22 Hz (1 mm amplitude peak to peak 2)
 - 22 Hz to 50 Hz (2 g acceleration)
- Underwater explosion shock tests (heavy weight high impact)
 - Tested in accordance with, Specification MIL-S 901C (NAVY) and HI
 - Test procedure n° HT 0458-TP-1 Original issue
 - Grade : «A»
 - Equipment classification : Hull Mounted external
 - Class : «I»
 - Test classification : Heavy Weight
 - Type : «A»
 - Tested for the US Navy (NCSC)

Electrical

Layouts	Maximum current rating per contact (A)	Maximum bundle current capacity per contact (A)
4 cts # 20	7.5	7.5
7 cts # 20	7.5	6.5
12 cts # 20	7.5	5.5
19 cts # 20	7.5	4.5
38 cts # 20	7.5	3.5
4 cts # 16	15	14
12 cts # 16	15	12
37 cts # 16	15	6.5
66 cts # 16	15	5
1 Ø 7 mm	100	100
4 # 8	45	35
1 Ø 18 mm	400	400
4 Ø 10+2#8	150 + 45	150 + 45

Layouts		Contacts sizes	Test voltage (Vrms)	Working voltage in external wet conditions ambient (Vrms)	Working voltage after subsea mating conditions complied (Vrms)
Shell size	Number of contacts				
1	4	# 20	2500	500	220
2	7	# 20	2500	500	220
	4	# 16	2500	500	220
	1	Ø 7 mm	3750	750	750
	12	# 20	2500	500	220
4	19	# 20	2500	500	220
	12	# 16	2500	500	220
	4	# 8	3750	750	360
5	37	# 16	2500	500	220
	1	Ø 18 mm	7500	1500	1500
6	68	# 16	2500	500	220
	4	Ø 10 mm	3750	750	360
7	38	# 20	2500	500	220

* After 5 mating/demating operations in clear water and suitable lubricate insulator (with silicone grease)



8810 Series

Ordering information

Standard connectors

shell size	Nbr. of contacts	plug (36H)	jam nut receptacle (10H)	cable connecting receptacle (11H)
1	4	8810-36H-1-04SA	8810-10H-1-04PA	8810-11H-1-04PA
2	7	8810-36H-2-07SA	8810-10H-2-07PA	8810-11H-2-07PA
2	4	8810-36H-2-04S	8810-10H-2-04P	8810-11H-2-04P
2	1	8810-36H-2-01SA	8810-10H-2-01PA	8810-11H-2-01PA
3	12	8810-36H-3-12SA	8810-10H-3-12PA	8810-11H-3-12PA
4	19	8810-36H-4-19SA	8810-10H-4-19PA	8810-11H-4-19PA
4	12	8810-36H-4-12SA	8810-10H-4-12PA	8810-11H-4-12PA
4	4	8810-36H-4-04SA	8810-10H-4-04PA	8810-11H-4-04PA
7	38	8810-36H-7-38SA	8810-10H-7-38PA	8810-11H-7-38PA
5	37	8810-36H-5-37SA	8810-10H-5-37PA	8810-11H-5-37PA
5	1	8810-36H-5-01SA	8810-10H-5-01PA	8810-11H-5-01PA
6	68	8810-36H-6-68SA	8810-10H-6-68SA	8810-11H-6-68PA
6	4 + 2	8810-36H-6-04SA	8810-10H-6-04PA	8810-11H-6-04PA

Note : Extra keyways x, y, z... are available on special request





Custom design receptacles

shell size	Nbr. of contacts	inverse pressure receptacle (12H)	thrubulkhead receptacle (14H)	square flange receptacle (15H)
1	4	8810-12H-1-04PA	8810-14H-1-04PA	8810-15H-1-04P
2	7	8810-12H-2-07PA	8810-14H-2-07PA	8810-15H-2-07P
2	4	8810-12H-2-04P	8810-14H-2-04PA	8810-15H-2-04P
2	1	8810-12H-2-01PA	8810-14H-2-01PA	8810-15H-2-01P
3	12	8810-12H-3-12PA	8810-14H-3-12PA	8810-15H-3-12P
4	19	8810-12H-4-19PA	8810-14H-4-19PA	8810-15H-4-19P
4	12	8810-12H-4-12P	8810-14H-4-12PA	8810-15H-4-12P
4	4	8810-12H-4-04PA	8810-14H-4-04PA	8810-15H-4-04P
7	38	8810-12H-7-38P	8810-14H-7-38P	8810-15H-7-38PA
5	37	8810-12H-5-37P	8810-14H-5-37PA	8810-15H-5-37P
5	1	8810-12H-5-01P	8810-14H-5-01PA	8810-15H-5-01P
6	68	8810-12H-6-68P	8810-14H-6-68PA	8810-15H-6-68P
6	4 + 2	8810-12H-6-04P	8810-14H-6-04PA	8810-15H-6-04P



8810 Series

Contact layouts (Plug back face view)

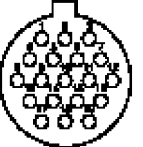
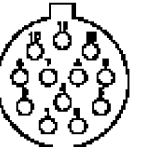
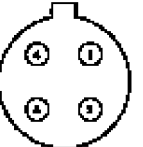
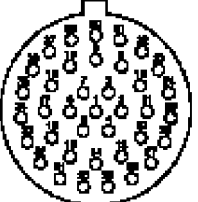
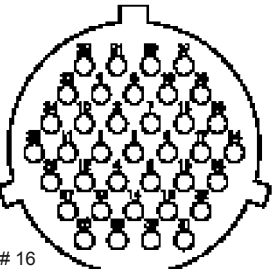
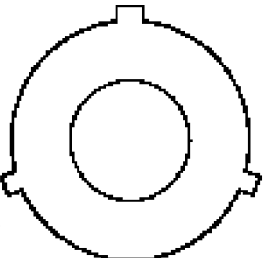
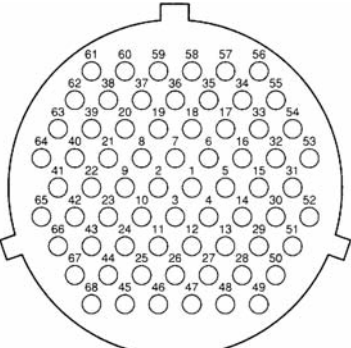
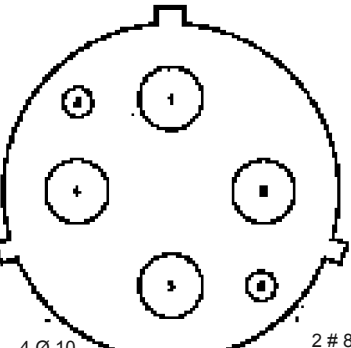
layouts		size 20 contacts	size 16 contacts	power contacts
shell size	number of contacts	contact diameter : 1.0 mm / 0.039 wire size max : 0.93 mm ² current rating : see below	contact diameter : 1.57 mm / 0.062 wire size max : 1.34 mm ² current rating per contact : 15A max.	contact diameter : see below wire size max : see below current rating : see below
1	4	4 # 20 0.93 mm ² 		
2	7 4 1	7 # 20 0.93 mm ² 	4 # 16 1.34 mm ² 	1 Ø 7 100 A 16 mm ² 
3	12	12 # 20 0.93 mm ² 		
4	19 12 4	19 # 20 0.93 mm ² 	12 # 16 1.34 mm ² 	4 # 8 45 A per contact 4 mm ² 
7	38	38 # 20 0.93 mm ² 		
5	37 1		37 # 16 1.34 mm ² 	1 Ø 18 400 A 185 mm ² 
6	68 4		68 # 16 1.34 mm ² 	4 Ø 10 150 A per contact 70 mm ² 2 # 8 45 A 45 mm ² 



8810 Series

Dimensions

Plugs (series 36H)

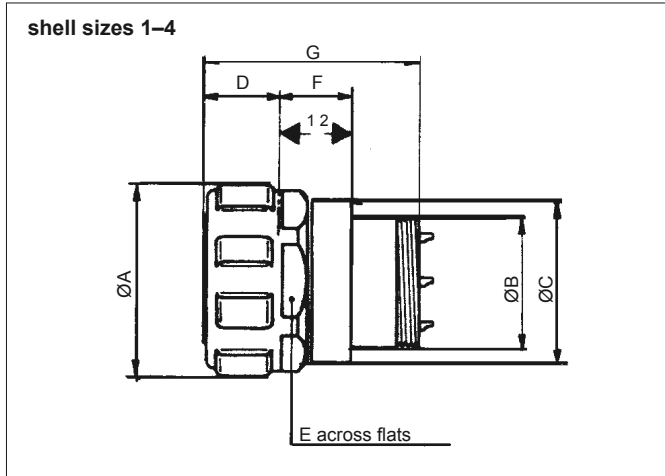

shell size	1	2	3	4
A Max	30.00 .181	33.50 .1319	39.00 .1535	43.50 .1713
B iso	16.8x0.5	20x0.75	25.5x0.75	30x0.75
C Max	24.20 .953	27.70 .1091	33.20 .1307	37.70 .1484
E Max	26 .1024	29 .1142	34 .1339	38 .1496
D Max	17.30 .681	17.30 .681	18.30 .720	19.30 .760
F Max	16.80 .661	16.80 .661	15.80 .662	14.80 .583
G Max	50.10 .1972	50.10 .1972	50.10 .1972	50.10 .1972

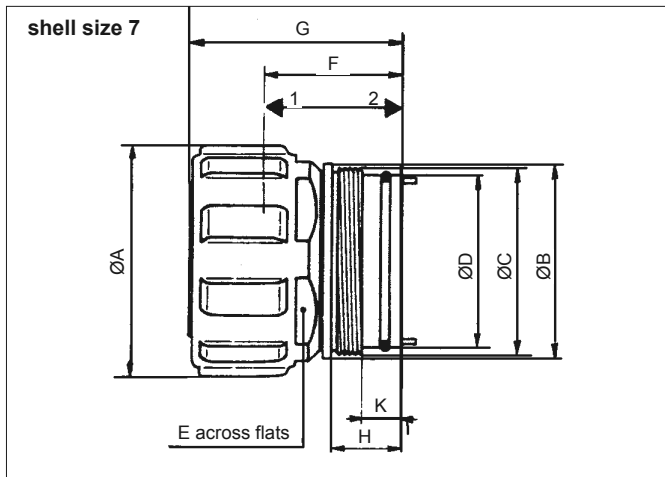

shell size	7
A Max	60.50 2.382
B Max	50.00 1.969
C iso	48x0.75
D	44.2f8 1.74f8
E Max	51.50 2.028
F Max	36.30 1.429
H Max	18.60 .732
G Max	56.00 2.205
K Max	10.70 .421

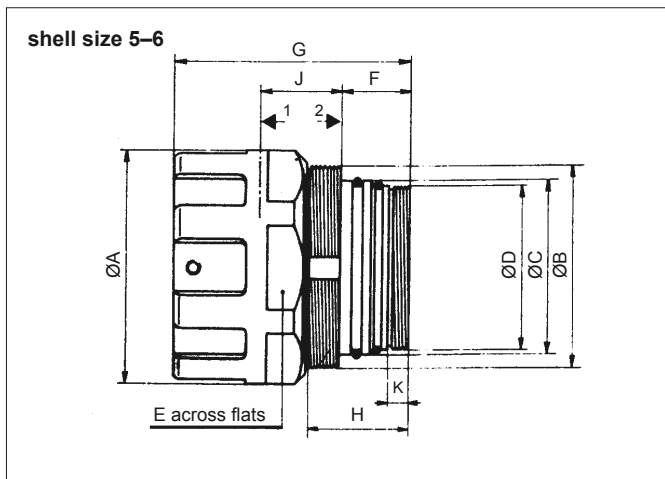

shell size	5	6
A Max	87.30 3.437	110.30 4.343
B iso	74x1.5	96x2
C	62.5 f7 2.46f7	82.5 f8 3.25f8
D iso	58x1.5	77x1.5
E Max	80.00 3.150	100.00 3.937
F Max	32.50 1.280	32.50 1.280
J Max	37.50 1.476	37.50 1.476
G Max	112.50 4.429	112.50 4.429
K Max	10.60 .417	10.60 .417
H Max	48.50 1.909	48.50 1.909



8810 Series

Jam nut receptacles (series 10H)

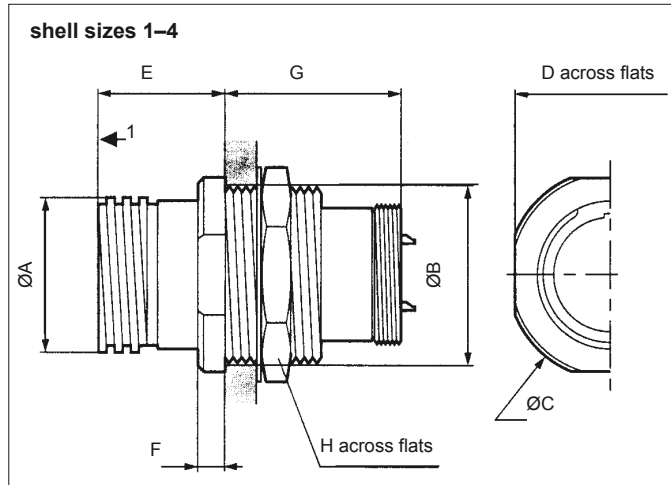

shell size	1	2	3	4
A Max	22.10 .870	25.10 .988	30.10 1.185	34.60 1.362
B iso	23.5x1	26.5x1	32x1	36.5x1
C Max	35.00 1.378	38.50 1.516	44.50 1.752	49.50 1.949
D Max	32.10 1.264	35.10 1.382	41.60 1.638	46.10 1.815
E Max	24.00 .945	24.00 .945	25.00 .984	26.00 1.024
F Max	5.00 .197	5.00 .197	5.00 .197	5.00 .197
G Max	34.50 1.358	34.50 1.358	34.50 1.358	34.50 1.358
H Max	27.00 1.063	30.00 1.181	36.00 1.417	41.00 1.614

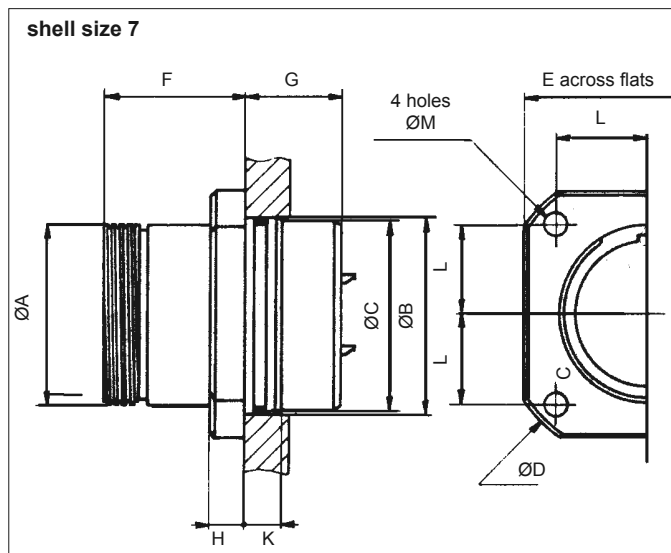

shell size	7
A Max	48.00 1.890
B (H8)	51.40 2.024
C	50.60 1.992
D Max	80.00 3.150
E Max	66.00 2.598
F Max	38.00 1.496
G Max	26.00 1.024
H Max	9.00 .354
K Max	9.50 .374
L	24.00 .945
M	5.70 .224

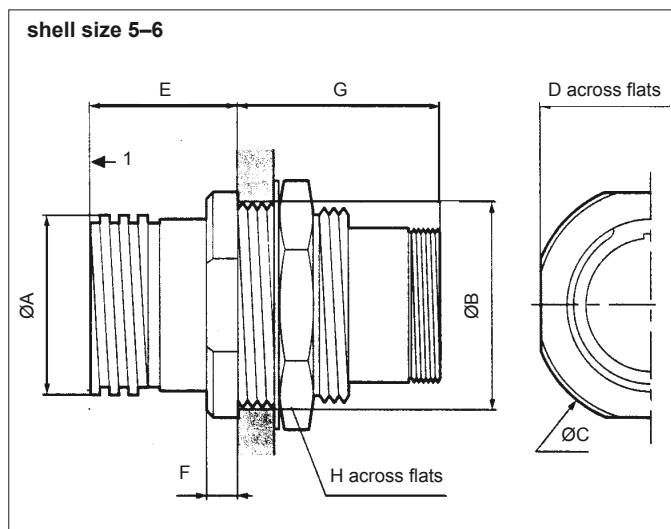

shell size	5	6
A Max	72.00 2.835	93 3.661
B iso	70x2	89x2
C Max	94.00 3.701	125.00 4.921
D Max	85.00 3.346	111.00 4.370
E Max	60.80 2.394	60.80 2.394
F Max	14.50 .571	14.50 .571
G Max	74.00 2.913	74.00 2.913
H Max	80.00 3.150	104.00 4.094



8810 Series

Cable connecting receptacles (series 11H)

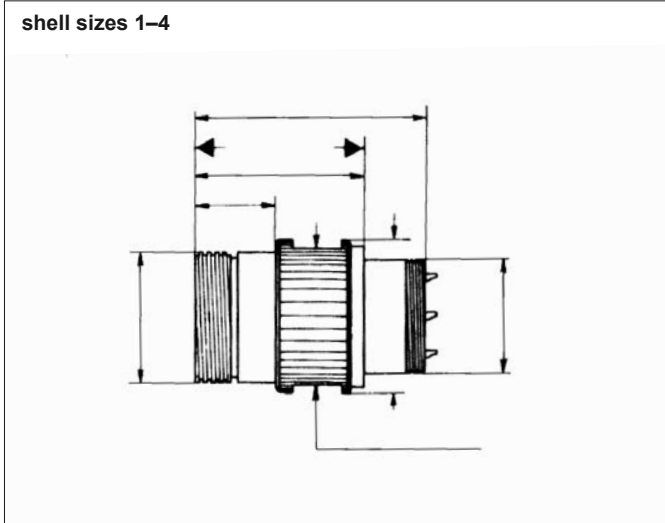

shell size	1	2	3	4
A Max	22.10 .870	25.10 .988	30.10 1.185	34.60 1.362
B iso	16.8x0.5	20x0.75	25.5x0.75	30x0.75
C Max	26.50 1.043	30.00 1.181	35.00 1.378	40.00 1.575
D Max	24.10 .949	27.10 1.067	32.10 1.264	36.10 1.421
E Max	19.00 .748	19.00 .748	20.00 .787	21.0 .827
F Max	42.10 1.657	42.10 1.657	43.10 1.697	44.10 1.736
G Max	58.10 2.287	58.10 2.287	59.10 2.327	60.10 2.366

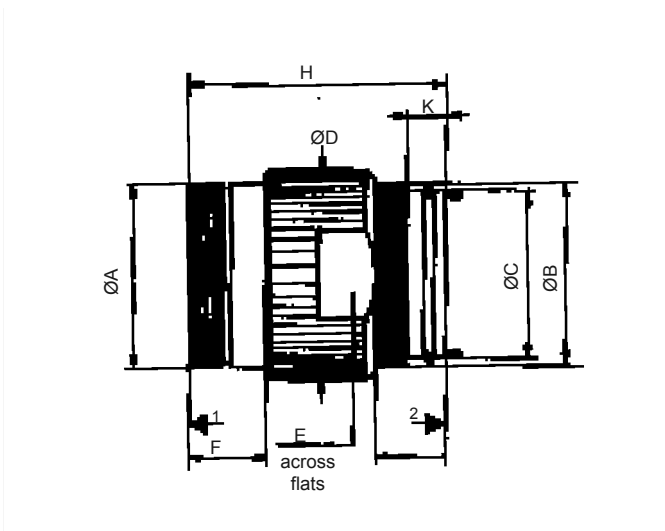

shell size	7
A Max	48.10 1.894
B iso	48x0.75
C	44.2f8 1.74f8
D Max	55.50 2.185
E Max	50.00 1.969
F Max	20.70 .815
G Max	18.60 .732
H Max	66.90 2.634
K Max	10.70 .421

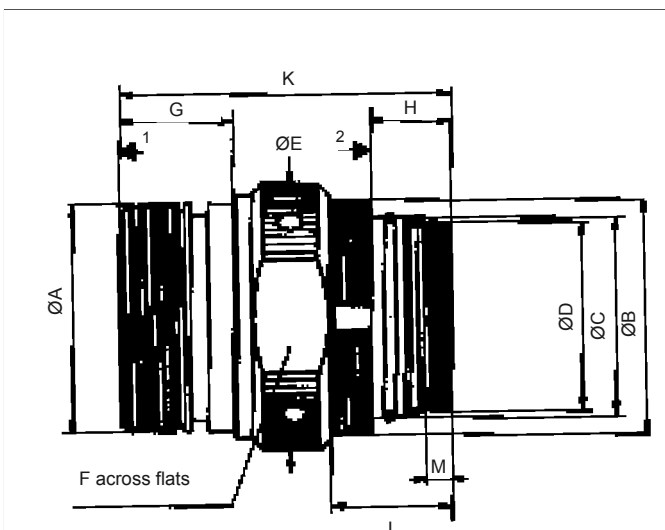

shell size	5	6
A Max	72.00 2.835	93.00 3.661
B iso	74x1.5	96x2
C	62.5f7 2.28f7	82.5f8 3.25f8
D iso	58x1.5	77x1.5
E Max	89.10 3.508	110.10 4.335
F Max	80.00 3.150	101.00 3.976
G Max	46.30 1.823	46.30 1.823
H Max	32.50 1.280	32.50 1.280
K Max	135.20 5.323	135.20 5.323
L Max	50.50 1.988	50.50 1.988
M Max	10.60 .417	10.60 .417



8810 Series

Square flange receptacles (series 15H)

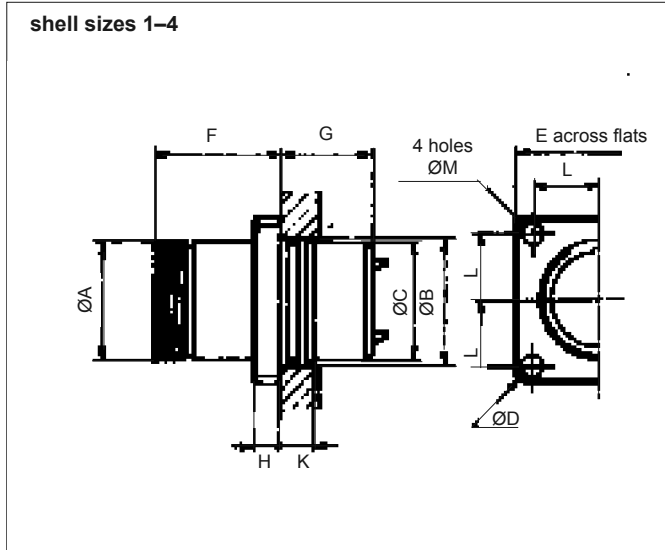

shell size	1	2	3	4
A Max	22.10 .870	25.10 .988	30.10 1.185	34.60 1.362
B (H8)	23.60 .929	26.60 1.047	32.10 1.264	36.60 1.441
C Max	22.90 .902	25.90 1.020	31.30 1.232	35.80 1.409
D Max	49.50 1.949	53.50 2.106	59.60 2.346	64.60 2.543
E Max	36.00 1.417	39.00 1.535	45.00 1.772	49.00 1.929
F Max	34.10 1.343	34.10 1.343	36.10 1.421	37.10 1.461
G Max	24.20 .953	24.20 .953	23.20 .913	23.20 .913
H Max	8.00 .315	8.00 .315	8.00 .315	8.00 .315
K Max	9.50 .374	9.50 .374	9.50 .374	9.50 .374
L Max	13.50 .531	15.00 .591	17.00 .669	19.00 .748
M	4.70 .185	4.70 .185	5.70 .224	5.70 .224

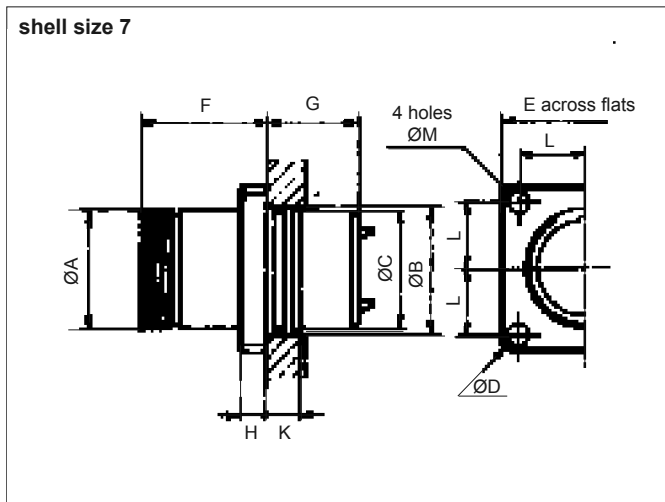

shell size	7
A Max	48.10 1.894
B (H8)	51.40 2.024
C	50.60 1.992
D Max	80.00 3.150
E Max	66.00 2.598
F Max	38.10 1.500
G Max	26.20 1.031
H Max	9.00 .354
K Max	9.50 .374
L	24.00 .945
M	5.70 .224

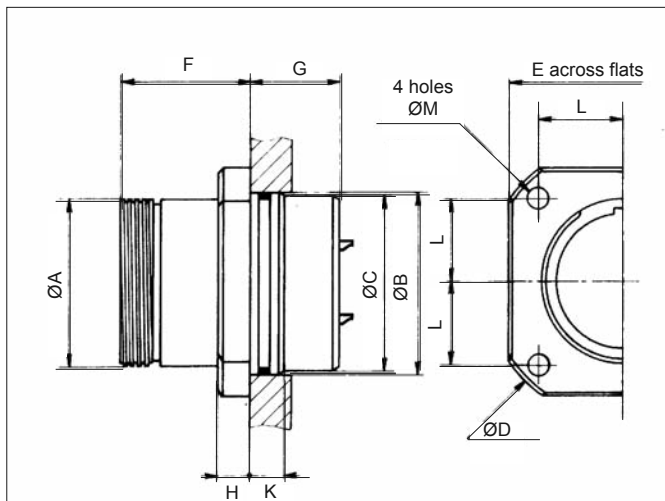

shell size	5	6
A Max	72.00 2.835	93.00 3.661
B (H8)	70.10 2.760	89.10 3.508
C	69.20 2.724	88.20 3.472
D Max	110.00 4.331	138.00 5.433
E Max	86.10 3.390	105.10 4.138
F Max	71.00 2.795	73.10 2.878
G Max	63.40 2.496	61.40 2.417
H Max	15.00 .591	15.00 .591
K Max	19.00 .748	19.00 .748
L	33.00 1.299	40.00 1.575
M	8.70 .343	10.70 .421



8810 Series

Standard endbells

Dimensions

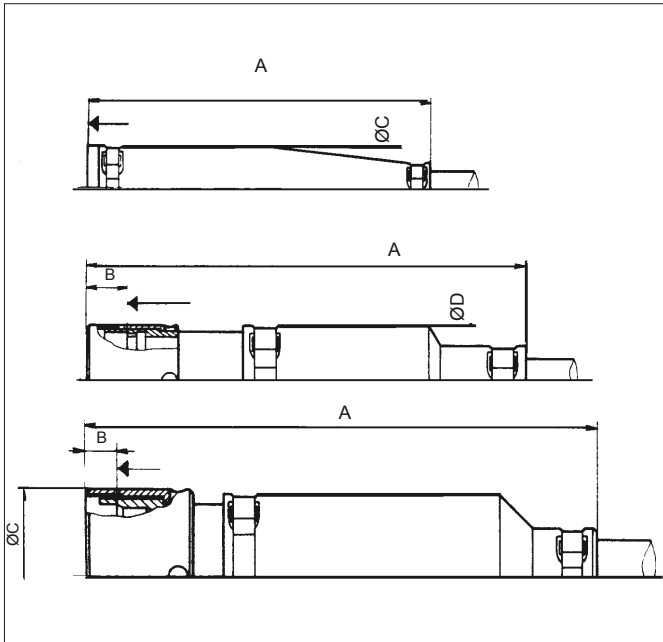

dimensions	shell size			
	1	2	3	4
A Max	105.00 4.134	119.00 4.685	135.00 5.315	149.00 5.866
C Max	26.00 1.024	29.40 1.157	35.70 1.406	40.70 1.602

dimensions	shell size	
	7	
A Max	210.00 8.268	
B Max	18.60 .732	
C Max	50.00 1.969	

dimensions	shell size	
	5	6
A Max	230.00 9.055	280.00 11.024
B Max	14.90 .587	14.90 .587
C Max	79.00 3.110	99.00 3.898

Ordering information

shell size	cable diameter	part number
1	7.8-8.8	8810-13-078-088
1	8.7-9.7	8810-13-087-097
1	9.5-10.5	8810-13-095-105
1	10.5-11.5	8810-13-105-115
2	9.3-10.3	8810-23-093-103
2	10.3-11.3	8810-23-103-113
2	11.0-12.0	8810-23-110-120
2	12.0-13.0	8810-23-120-130
3	9.5-11.0	8810-33-095-110
3	11.0-12.5	8810-33-110-125
3	12.5-14.0	8810-33-125-140
3	14.0-15.5	8810-33-140-155
4	11.2-12.7	8810-43-112-127
4	12.7-14.2	8810-43-127-142
4	14.0-15.5	8810-43-140-155
4	15.5-17.0	8810-43-155-170

shell size	cable diameter	part number
7	18.0-20.0	8810-73-180-200
7	20.0-22.0	8810-73-200-220
7	22.0-24.0	8810-73-220-240
7	24.0-26.0	8810-73-240-260
7	26.0-28.0	8810-73-260-280
5	15.0-20.0	8810-53-150-200
5	20.0-25.0	8810-53-200-250
5	25.0-30.0	8810-53-250-300
5	30.0-35.0	8810-53-30-350
6	22.0-28.0	8810-63-220-280
6	28.0-34.0	8810-63-280-340
6	34.0-40.0	8810-63-340-400
6	40.0-45.0	8810-63-400-450
6	45.0-50.0	8810-63-450-500

Adapters are available to enable next larger shell size clamp to be fitted - Please consult us.

In shell size 1 to 7
Custom design end-bells are developed for other cable dimensions, please consult us



8810 Series

Longitudinally sealed Endbells

Dimensions

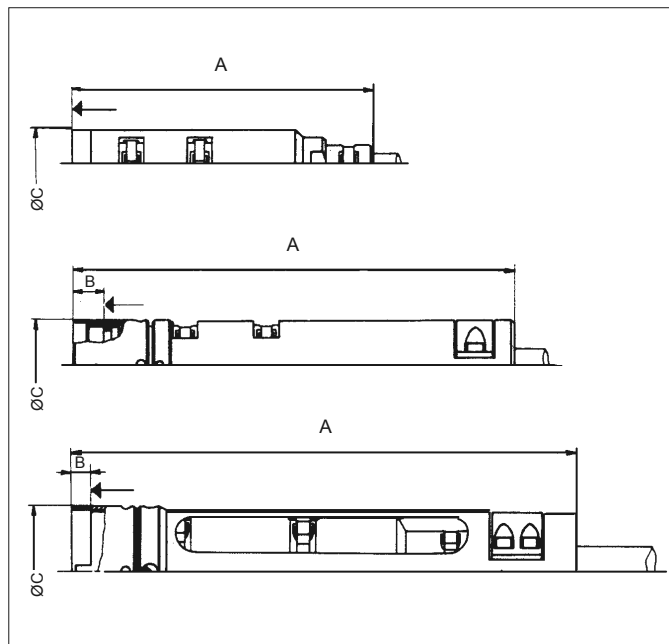

dimensions	shell size			
	1	2	3	4
A Max	146.00 5.748	153.00 6.024	160.00 6.299	167.00 6.575
B Max	—	—	—	—
C Max	24.70 .972	28.20 1.110	33.70 1.327	38.20 1.504

dimensions	shell size	
	7	
A Max	2430 9.567	
B Max	17.90 .705	
C Max	50.00 1.969	

dimensions	shell size	
	5	6
A Max	383.00 15.079	392.00 15.433
B Max	15.00 .591	15.00 .591
C Max	80.10 3.154	90.00 3.898

Ordering information

shell size	cable diameter	part number	
1	7.8-8.8	8810-13-	078-088
1	8.7-9.7	8810-13-	087-097
1	9.5-10.5	8810-13-	095-105
1	10.5-11.5	8810-13-	105-115
2	9.3-10.3	8810-23-	093-103
2	10.3-11.3	8810-23-	103-113
2	11.0-12.0	8810-23-	110-120
2	12.0-13.0	8810-23-	120-130
3	9.5-11.0	8810-33-	095-110
3	11.0-12.5	8810-33-	110-125
3	12.5-14.0	8810-33-	125-140
3	14.0-15.5	8810-33-	140-155
4	11.2-12.7	8810-43-	112-127
4	12.7-14.2	8810-43-	127-142
4	14.0-15.5	8810-43-	140-155
4	15.5-17.0	8810-43-	155-170

insert appropriate contact number - see page contacts layouts.

shell size	cable diameter	part number	
7	18.0-20.0	8810-73-	180-200
7	20.0-22.0	8810-73-	200-220
7	22.0-24.0	8810-73-	220-240
7	24.0-26.0	8810-73-	240-260
7	26.0-28.0	8810-73-	260-280
5	15.0-20.0	8810-53-	150-200
5	20.0-25.0	8810-53-	200-250
5	25.0-30.0	8810-53-	250-300
5	30.0-35.0	8810-53-	30-350
6	22.0-28.0	8810-63-	220-280
6	28.0-34.0	8810-63-	280-340
6	34.0-40.0	8810-63-	340-400
6	40.0-45.0	8810-63-	400-450
6	45.0-50.0	8810-63-	450-500

insert appropriate contact number - see page contacts layouts.

Adapters are available to enable next larger shell size clamp to be fitted

For shell size 1 to 7

Custom design endbells are developed for other cable OD dimensions, please consult us.

For shell size 4 with a cable OD >17mm 0.669, the adapter 8810 6524 has to be used.