

SPACECRAFT COMPONENTS CORP.

S e r v i n g C o n n e c t o r U s e r s S i n c e 1 9 6 2

KwikSnap CONNECTORS

SCTAC 

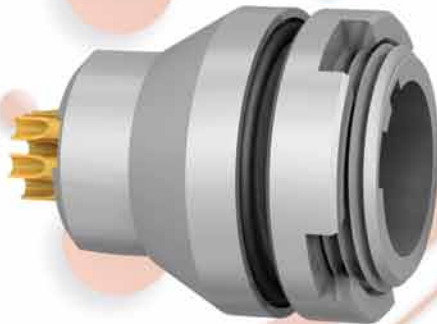
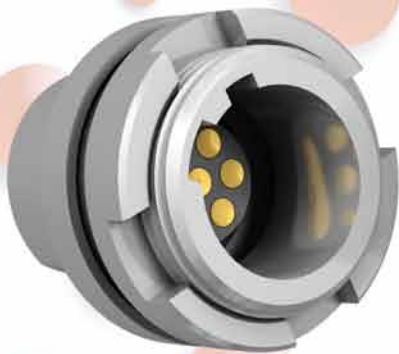

Snap-On Locking

10,000 Mating Cycles

Spring Loaded Contacts

EMI Shielded

IP67 When Mated & Unmated



**SPACECRAFT
COMPONENTS CORP.**

ORDERING INFORMATION

SCTAC 1 07 S N Z 1

SERIES PREFIX ————

STYLE ————

1 Straight Plug[▲]
 2 Receptacle - Rear Panel Mounting
 3 Receptacle - In-Line[▲]
 4 Receptacle - Front Panel Mounting
 5 Receptacle - Rear Panel Mounting[▲]
 6 Plug - Front Panel Mounting
 7 Plug - Rear Panel Mounting[▲]
 ▲ Banding or Overmolding application.

NO. OF CONTACTS ————

07 7 Contacts
 13 13 Contacts
 19 19 Contacts

TERMINATION ————

S Solder Cup (24-28 AWG)
 B P.C. Tail Termination, Diameter = .024 (0.06)
 P.C. Tail Length = .118 (3.00)

PIN PLACEMENT

BLANK Standard Contacts
1 Center Pin Advanced by 1mm

PLATING

B Black Oxide Coating, Material: Stainless Steel 303
C Black Oxide Coating, Material: Stainless Steel 316
N Nickel Plated, Material: Aluminum Alloy
P Passivated, Material: Stainless Steel 303
R Passivated, Material: Stainless Steel 316
W Tungsten Carbide Black, Material: Stainless Steel 303
X Tungsten Carbide Black, Material: Stainless Steel 316
Z Zinc Cobalt Plated, Material: Aluminum Alloy

POLARIZATION
 See Illustration below

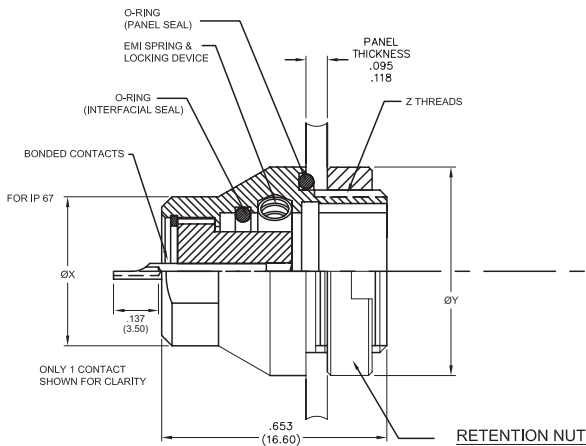

SCTAC2* Receptacle, Rear Panel Mount

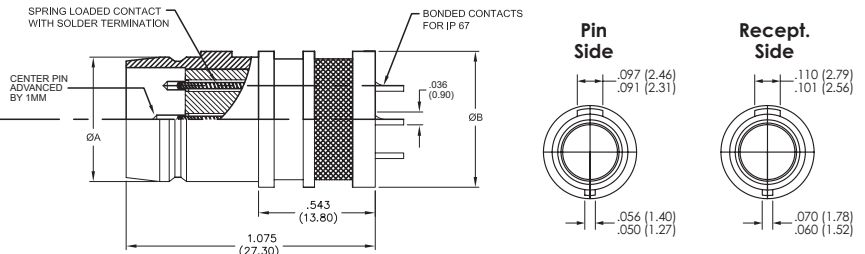
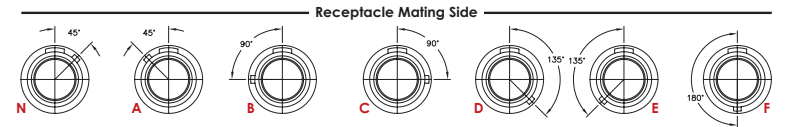
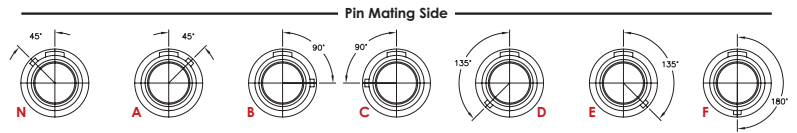

SCTAC1* Straight Plug

RECEPTACLE WITH SOCKET CONTACTS

NO. OF CONTACTS	ØX	ØY	Z
7	.433 (11.00)	.606 (15.40)	M12 x 0.75
13	.543 (13.80)	.724 (18.40)	M15 x 0.75
19	.582 (14.80)	.591 (19.40)	M16 x 0.75

PLUG WITH PIN CONTACTS

NO. OF CONTACTS	ØA	ØB
7	.327 (8.30)	.402 (10.20)
13	.445 (11.30)	.512 (13.00)
19	.484 (12.30)	.551 (14.00)

PANEL CUT-OUT DIMENSIONS

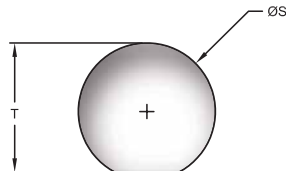

NO. OF CONTACTS	ØS + .004 (.10) - .000 (.00)	T + .004 (.10) - .000 (.00)
7	.480 (12.20)	.465 (11.80)
13	.598 (15.20)	.579 (14.70)
19	.638 (16.20)	.618 (15.70)

INSERT CONFIGURATIONS

Plug Mating Side

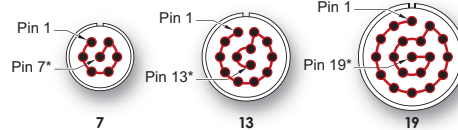

* Last pin advanced by 1mm.

Receptacle Mating Side

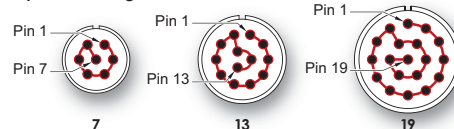

Number of .031Ø Spring Loaded Pin Contacts

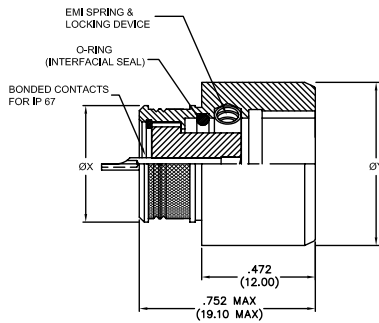

IN-LINE RECEPTACLE
SCTAC3*

NO.OF CONTACTS	ØX	ØY
7	.402 (10.20)	.512 (13.00)
13	.512 (13.00)	.630 (16.00)
19	.551 (14.00)	.669 (17.00)

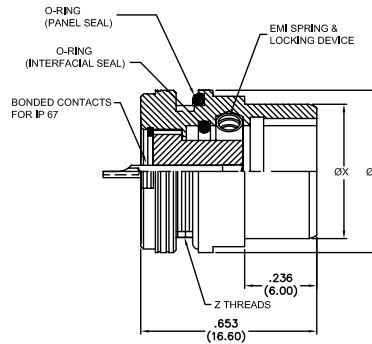

RECEPTACLE - FRONT PANEL MOUNTING
SCTAC4*

NO.OF CONTACTS	ØX	ØY	Z THREADS
7	.472 (12.00)	.606 (15.40)	M12 x 0.75
13	.591 (15.00)	.724 (18.40)	M15 x 0.75
19	.630 (16.00)	.591 (19.40)	M16 x 0.75

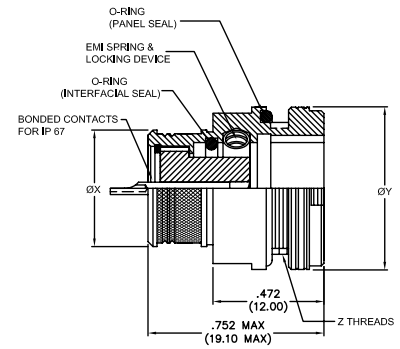

RECEPTACLE - REAR PANEL MOUNTING
SCTAC5*

NO.OF CONTACTS	ØX	ØY	Z THREADS
7	.402 (10.20)	.606 (15.40)	M12 x 0.75
13	.512 (13.00)	.724 (18.40)	M15 x 0.75
19	.551 (14.00)	.591 (19.40)	M16 x 0.75

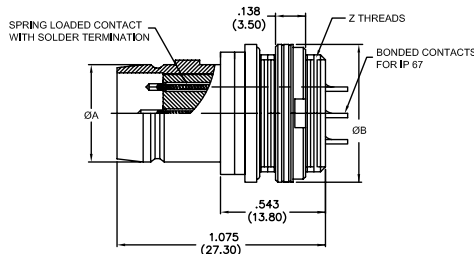

PLUG - FRONT PANEL MOUNTING
SCTAC6*

NO.OF CONTACTS	ØX	ØY	Z THREADS
7	.327 (8.30)	.606 (15.40)	M12 x 0.75
13	.445 (11.30)	.724 (18.40)	M15 x 0.75
19	.484 (12.30)	.591 (19.40)	M16 x 0.75

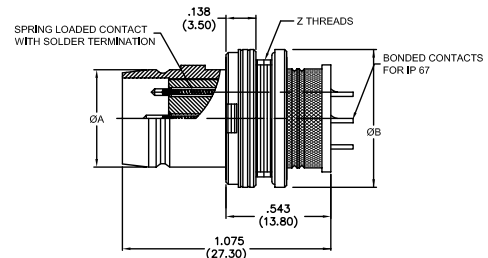

PLUG - REAR PANEL MOUNTING
SCTAC7*

NO.OF CONTACTS	ØX	ØY	Z THREADS
7	.327 (8.30)	.606 (15.40)	M12 x 0.75
13	.445 (11.30)	.724 (18.40)	M15 x 0.75
19	.484 (12.30)	.591 (19.40)	M16 x 0.75

Over-molded cable assemblies are available.

APPLICABLE DOCUMENTS

Base Material - Standard Specifications

MIL-M-24519	Moulding Plastics, Electrical, Thermoplastic
ASTM-B-16	Free-Cutting Brass Rod, Bar and Shapes
ASTM-B-121	Leaded Brass Plate, Sheet, Strip, and Rolled Bar
ASTM-B-139	Standard Specification for Phosphor Bronze Rod, Bar, and Shapes
ASTM-B-196	Copper-Beryllium Alloy Rod and Bar
ASTM-B-197	Copper Beryllium Alloy Wire
ASTM-B-209	Aluminum and Aluminum-Alloy Sheet and Plate
ASTM-B-455	Standard Specification for Copper-Zinc-Lead Alloy (Leaded-Brass) Extruded Shapes
ASTM-A-582	Free-Machining Stainless Steel Bars and Heat Resisting Steel Bars

Plating - Standard Specifications

AMS-C-26074	Coatings, Electroless Nickel
MIL-STD-869	Standard Specification for Flame Spraying
ASTM-B-488	Electrodeposited Coatings of Gold
ASTM-A-967	Chemical Passivation Treatments for Stainless Steel Parts
QQ-N-290	Nickel Plating, Electrodeposited

Test Procedures

EIA 364	Test Methods For Electrical Connectors
UL94	Test Methods For Flammability Rating
IEC 529	Degrees of protection provided by enclosures
IEC 512	Electromechanical components for electronic equipment

CIRCULAR CONNECTOR TECHNICAL CHARACTERISTICS

General

Number of Contacts	7, 13, 19
Receptacle Contact Termination	Solder Cup, Straight PCB
Plug Contact Termination	Solder Cup
AWG Contact	28-24
Cable Diameter Range	Max 6 mm (7 contacts) Max 7.5 mm (13 contacts) Max 8.5 mm (19 contacts)

Materials and Plating

Inner Insulators	GE Ultem 2300 Black
Interface Insulators	GE Ultem 2300 Black
Housing	(see table 1 below)
Locking Spring	316BRT Stainless Steel

Materials and Plating

Plug Contact Terminations (<i>solder cups</i>)	CnZn36Pb3 plated 5µm Sn/2.5µm Ni or plated Au per ASTM-B-488
Spring Contact Clip	CuBe as per ASTM-B-197 plated with Au as per ASTM-B-488
Spring Element	Stainless Steel AISI 302 passivated as per ASTM-A-967
Receptacle Contact	CnZn36Pb3 plated with Au as per ASTM-B-488
Weight	Related to standard connectors configuration (see table 2 below)

Table 1 - Plating

MATERIAL	Aluminium Alloy 6061T6		Stainless Steel		
	Z	N	P, R	B, C	W, X
PLATING	Zn/Co on Chemical Ni Black 5 µm SAE AMS-C-26074 Class 1	Chemical Ni Matt Grey 20 µm SAE AMS-C-26074 Class 1 Grade A	Passivation Matt Grey as per ASTM-A-967	Coating Oxide Black as per MIL-DTL-13924D	Metal Spray- ing Tungsten Carbide Black 1-5 µm as per MIL-STD-869

Table 2 - Connector Weight

SIZE	MATERIAL	PLUG	RECEP.
07	Aluminum	4.0	4.8
	Stainless Steel	7.6	10.2
13	Aluminum	6.7	6.5
	Stainless Steel	11.4	13.5
19	Aluminum	8.4	7.1
	Stainless Steel	13.7	15.1

Weight measured in grams.

ELECTRICAL CHARACTERISTICS

EMI Shielding	360° shield coverage
Current Rating	3A@25°C for each contact according to IEC 512-3
Dielectric Withstanding Voltage (between contacts)	500 Vrms at sea level and 150 Vrms at 21336m according to EIA 364.20
Contact Resistance (low level)	<25 mΩ for each contact according to EIA 364.6
Insulation Resistance	5000 MΩ @ 500V d.c. according to EIA364.21
Electrical Bonding Resistance	(see table 3)

Table 3 - Electrical Bonding Resistance vs. Material/Surface Treatment

Z	N	P, R	B, C	W, X
500 - 800 mΩ	5 - 8 mΩ	5 - 8 mΩ	150 - 250 mΩ	20 - 40 mΩ

MECHANICAL AND ENVIRONMENTAL CHARACTERISTICS

Temperature Range	-55°C +85°C
Temperature cycling	EIA364.32 Method A
Salt Spray	EIA364.26 Condition A - mated connectors
Humidity	EIA364.31 Method IV
IP Level	67 mated and unmated IEC 529
Vibration	EIA364.28 Condition III
Shock	EIA364.27 Condition G
Contact Spring Force (single contact)	Max 1.5 [N]
Connector Mating / Unmating Force	EIA364.09 (see table 4)

Table 4 - Mating / Unmating Forces

SIZE	MATERIAL	MATING [N]		UNMATING [N]		LIFE CYCLES
		Min	Max	Min	Max	
07	Aluminum					2,000
	Stainless Steel	20	35	20	40	8,000
13	Aluminum					2,000
	Stainless Steel	20	35	20	40	10,000
19	Aluminum					2,000
	Stainless Steel	25	35	25	45	10,000



**SPACECRAFT
COMPONENTS CORP.**

Headquarters
3040 Clayton Street
North Las Vegas, NV 89032

Phone: 702.851.7600
Fax: 702.851.7620

Email: salesinfo@spacecraft.com
Web: www.spacecraft.com

Florida Office

4577 Nob Hill Road
Suite 106
Sunrise, FL 33351
Tel: 954.748.4540
Fax: 954.748.4128

Arizona Office

519 W. Lone Cactus Dr.
Suite 401
Phoenix, AZ 85027
Tel: 623.580.1162
Fax: 623.580.1165

Italy Office

Spacecraft Components, Sp A
Milan, Italy
+39 (335) 719.4512

Mexico Office

Av. Constituyentes 13-6 Col. Pueblo Nuevo
Queretaro, Qro 76900
+52 442 341 69 63

OCT.2012
SF-171

COMPILED AND PRODUCED BY SPACECRAFT COMPONENTS CORP.
©2012 SPACECRAFT COMPONENTS CORP., NORTH LAS VEGAS, NV 89032